

2009 GUIDE TO TOWING

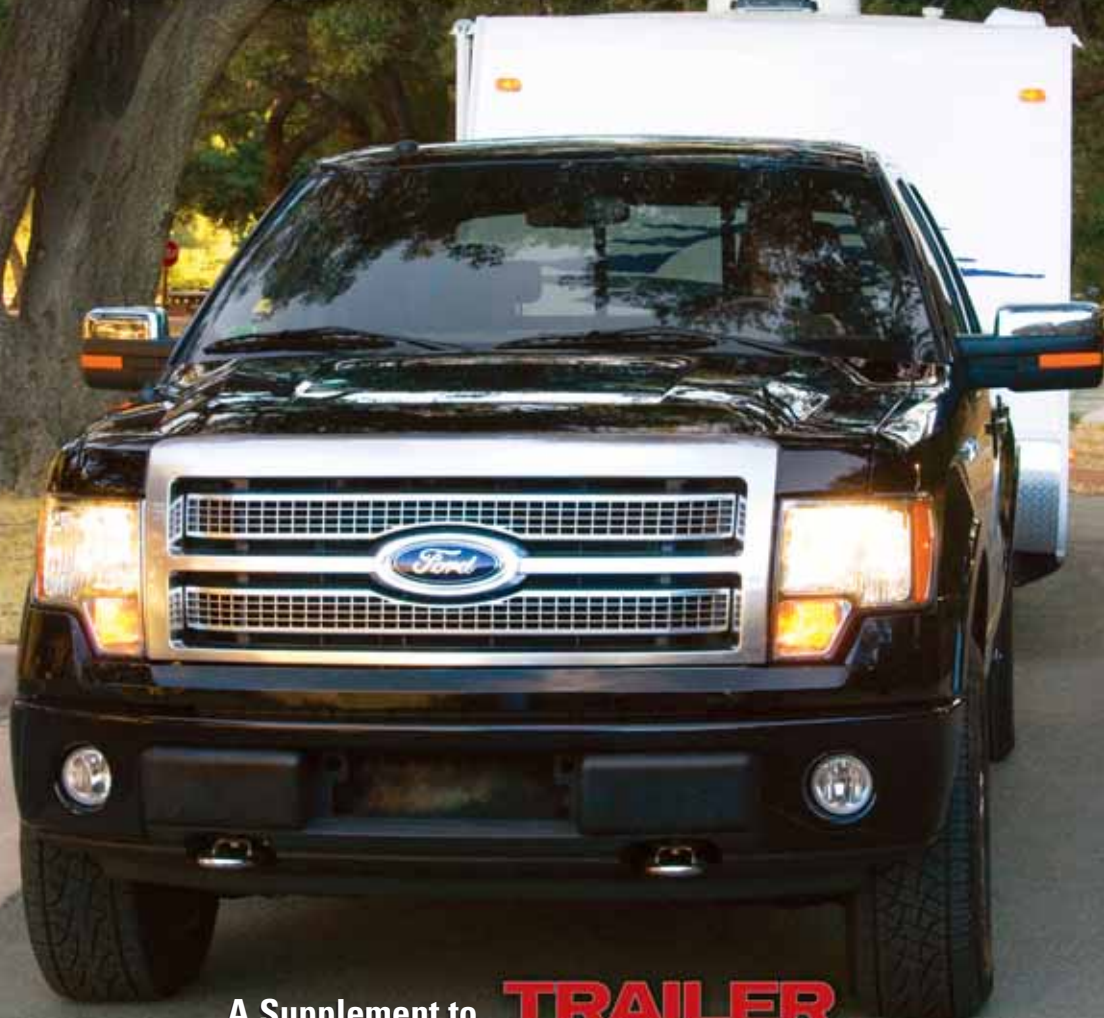

A Supplement to

TRAILER
FOLLOW THE ROAD TO ADVENTURE
LIFE

OFFICIAL TRAILER TOW RATINGS

■ NEW FOR 2009

■ TOW-VEHICLE SELECTION

■ ANATOMY OF A TOW PACKAGE

■ HITCHING UP

■ TIPS FOR TOWING

■ BRAKE CONTROLLERS

Go To: **TRAILER**
FOLLOW THE ROAD TO ADVENTURE
LIFE.com

User Guide

Contents

ALL-NEW '09 F-150
MAN, TRAILERS ARE LIKE
WILD
ANIMALS.

**They're always trying
to get away from you.**
Until now. Trailer sway control, standard.





FIND OUT MORE AT FORDVEHICLES.COM





- 5 Choose Wisely**
Tow-vehicle selection includes careful consideration of weights and measures
- 10 Towing 2009**
With fuel economy taking center stage for manufacturers, Ford introduces refined F-150s
- 15 How to Use This Guide**
- 16 2009 Tow Ratings**
- 31 Hitching Up**
Choosing the correct equipment for towing
- 36 A Hitch for All Reasons**
Hensley offers a variety of unique hitches for travel trailers and fifth-wheels
- 37 Trailer-Brake Control**
Latest technology improves safety and reliability
- 40 Anatomy of a Towing Package**
- 44 Towing Tips**
Logging time behind the wheel before heading out helps make the towing process smoother
- 46 Rules of the Road and Towing Laws**

2009 Guide to Towing Sponsors

Ford Motor Company

(800) 392-3673

www.ford.com

Hensley Manufacturing Inc.

(800) 410-6580

www.hensleymfg.com

TRAILER LIFE

EDITORIAL

PUBLISHER

BOB LIVINGSTON

EDITOR

KRISTOPHER BUNKER

MANAGING EDITOR

MARLEEN CANNIFF

CREATIVE

ART DIRECTOR

MIRANTE ALMAZAN

EDITORIAL/BUSINESS OFFICE

2575 VISTA DEL MAR DRIVE, VENTURA, CA 93001

TEL (805) 667-4100 FAX (805) 667-4484

ADVERTISING

Ventura, California

VP/NATIONAL SALES

TERRY THOMPSON

BUSINESS MANAGER

DENIELLE STERNBURG

P.O. Box 8510, VENTURA, CA 93002

TEL (805) 667-4100 FAX (805) 667-4379

Elkhart, Indiana

MIDWEST SALES DIRECTOR

CHUCK LASLEY

NATIONAL ADVERTISING SALES

TACY HENDERSHOT

NATIONAL ADVERTISING SALES

LOU CICIRELLI

2300 MIDDLEBURY STREET, ELKHART, IN 46516

TEL (574) 295-7820 FAX (574) 522-0418

Seattle, Washington

NATIONAL SALES

SCOTT OAKES, JOHN MARGIANO

1818 WESTLAKE AVENUE N, #420

SEATTLE, WA 98109

TEL (206) 283-9545 FAX (206) 283-9571

Detroit, Michigan

CROMPTON HOLDINGS

SCOTT CROMPTON

2031 FERNWAY DRIVE

MONTGOMERY, AL 36111

TEL (334) 613-2040 FAX (334) 356-7740

TRAILER LIFE IS A REGISTERED TRADEMARK OF AFFINITY GROUP INC. COPYRIGHT 2009 BY AFFINITY GROUP INC. ALL RIGHTS RESERVED. TRAILER LIFE (USPS #454-970) IS PUBLISHED MONTHLY BY TL ENTERPRISES INC. SUBSCRIPTION PRICE, U.S. AND POSSESSIONS: 1 YEAR, \$15.97; 2 YEARS, \$27.97. ALL OTHER COUNTRIES, ADD \$12 PER YEAR.

FOR MORE INFORMATION, VISIT OUR WEB SITE AT

www.trailerlife.com



Choose Wisely

Paying close attention to the tow ratings is necessary to make appropriate model and option choices

BY DUNCAN O'NEAL

With so many choices available in tow vehicles, selecting the one that works best for your application may seem like a daunting task. There are many variables to consider, including budget, brand and towing capacity, and it's important to examine them all carefully before making a purchase. Going through the effort to better understand each variable and to account for all of them up front will lead to a more pleasant trailering experience later.

Weight Matters

The tow-ratings guide in this section lists the maximum tow ratings for vehicles with specific

equipment, but many buyers interpret the maximum vehicles' tow ratings with far too much optimism. Always check the manufacturer's figures before making a purchase. The following is an explanation of the terms you need to know which, when combined with readings from a public scale and your own calculator, should help you determine the correct tow rating for the tow vehicle you plan to buy.

Gross Combination Weight Rating (gcwr):

The total allowable weight of the truck, the trailer, the cargo in each, fluids and occupants.

Gross Vehicle Weight Rating (gvwr):

The total allowable weight for the vehicle, including

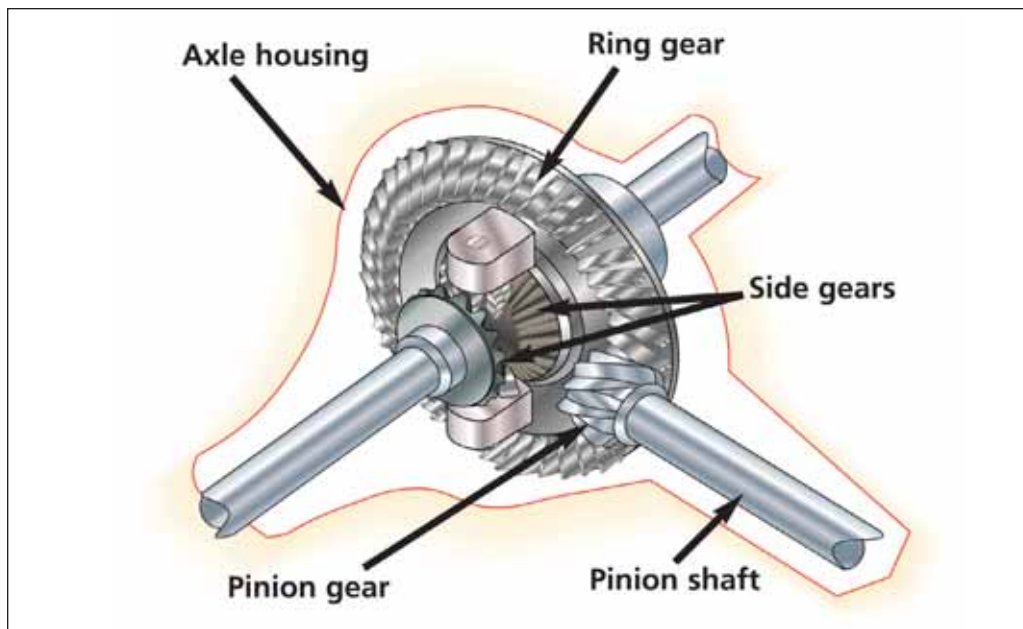

Choosing the proper axle ratio is vital to performance and fuel economy. The axle ratio indicates the proportion between the pinion-shaft and ring-gear revolutions.

fluids, options, hitch, cargo and trailer-hitch weight. The trailer's gvwr is the total allowable weight of the trailer, fluids, occupants, options and cargo.

Gross Axle Weight Rating (gawr): The total allowable weight on any given individual axle. This includes the weight of the tires, wheels, brakes and the axle itself.

Maximum Tow Rating: The manufacturer's weight limit for towed loads. For conventional trailers, this normally includes a hitch-weight limit as well; for fifth-wheels, the pin weight is applied to the truck's gvwr and its rear-axle gawr.

Trailer and Tow Rig Matchup

The gvwr and gawr for all motor vehicles are listed on the data plate, typically affixed to the driver's door frame, fuel door, glove box, end of the dashboard or other easy-to-access location. Brochures and window stickers may be inaccurate. All trailers should have a weight sticker — normally found in an interior cabinet — that lists the trailer's Unloaded Vehicle Weight (uvw), gvwr, weight added by freshwater and LP-gas and the resulting cargo carrying capacity.

In many cases, optional equipment — such as air-conditioning units, generators and the fuel they run on — sneaks onboard after weighing, and may not be reflected on the sticker. And don't forget the fuel-fill tanks that some SURVs offer for campsite refueling of motorcycles and ATVs.

Recently enacted Recreational Vehicle Industry

Association (RVIA) weight label requirements are more inclusive of dealer-added options and make it easier for buyers to have access to more accurate weight figures.

The gvwr figures are neither guidelines nor estimates; they are limits, and there are numerous valid reasons the manufacturer arrived at the figures given. If you think these figures are "close enough" or have a fudge-factor percentage built in, think again. Your warranty coverage, and your safety, may be at risk.

The only sure-fire way to find out what your trailer weighs is to load it as usual for a trip, right down to the towels and trinkets, and weigh it at a public scale. Without forming a long queue of commercial trucks waiting their turns at the scale, get the hitch weight, axle weight and total weight. Assuming that the axle weight is below the gawr, the total is below the gvwr and the hitch weight is below the maximum given for your tow vehicle, you can then move on to tow-vehicle selection.

For a new trailer, consult the weight sticker on the unit of your choice on a dealer's lot and refer to the uvw and cargo carrying capacity (ccc).

Estimate how much cargo you will add, being mindful of the gvwr, and use that number while selecting a tow vehicle.

To a lesser extent, tow-vehicle weight is variable as well. Brochures and tow guides frequently list how much a truck weighs, but this number generally applies to the most basic model in that

configuration, without any options. In some cases, distinctions are made by engine, transmission, drive system (2WD or 4WD/AWD) and, in other cases, by cab or bed styles. If the dealer does not have a vehicle equipped as you want that is available to weigh, or cannot provide option weights, you can form rough estimates — but exact figures are the only way to be certain.

Bigger engines add weight, diesels more so because they come with additional accessories (700 pounds more than the standard gas engine is common). Add up to 175 pounds for an optional transmission, about 400 pounds for 4WD and a bit less than 300 pounds for longer beds. Then add other options like luxury-trim levels, as all those electric motors add up. The towing package and hitch could add another 100 pounds, and larger wheels and tires can also have an effect.

Following is how to calculate the realistic towing capacity of the vehicle that interests you.

For example, consider a fictional one-ton longbed, diesel, extended-cab, 2WD, single-rear-wheel pickup set up for towing. We'll arbitrarily assign it a gwwr of 9,900 pounds, a front gawr of

5,000 pounds, a rear gawr of 6,824 pounds, a gcwr of 23,000 pounds and a quoted maximum tow rating of 17,000 pounds.

As is often the case in single-rear-wheel trucks, the rear axle's gawr on this truck is derived from each tire's maximum load of 3,412 pounds. Pick-ups such as this normally start at more than 6,000 pounds, and with a diesel, automatic and nice trim, figure that with a full tank of fuel and hitch, this unit weighs 7,000 pounds. If we add two "standard-size" people (154 pounds each), a few tools and some cargo, it weighs 7,500 pounds. That is split to 4,000 pounds on the front axle, and 3,500 pounds on the rear axle.

The first thing you should have noticed is that the maximum tow rating cannot apply with the truck fully loaded because gcwr (23,000) minus gwwr (9,900) leaves 13,100 pounds — about two tons less than quoted towing ability. After adding options and people to the example truck, and subtracting that value (7,500) from gcwr (23,000), the effective working tow rating of the truck becomes 15,500 pounds, about 1,500 pounds less than the truck's quoted maximum towing rating.

**Smooth Air Ride
& Easy Removal**

All in One 5th Wheel Hitch!

The BD3 from Hensley Mfg. gives you

- 97% Reduction in Bouncing
- Less Stress in your 5th Wheel and Truck
- 4-way hitch head articulation
- Easy Removal in 2 pieces
- Capacity up to 18,000 lbs.
- Made in USA Quality

Short Bed Owners... ask about our New CabSaver System. No More Sliders!

TRAILERSAVER

The Name Says it All

HENSLEY

800.410.6580 • www.TrailerSaver.com

However, you have yet to check all the numbers and verify that a 15,500-pound trailer will work. If that trailer is a fifth-wheel and has 20 percent of its weight on the pin, that adds 3,100 pounds to the back of the truck. This would make the truck overweight — its 7,500-pound ready-to-roll weight plus the 3,100 pounds on the pin equals 10,600 pounds — 700 pounds more than the truck's gcwr, and just 224 pounds shy of the rear-axle limit of 6,824 pounds.

SUVs and other non-pickup tow rigs cannot escape scrutiny. The vehicle's loaded weight, with the anticipated load of passengers aboard, must be subtracted from the gcwr to determine the realistic tow rating.

Other Factors to Consider

The tow-ratings chart lists vehicle-towing maximums segregated by engine, cab style, drive and single- or dual-rear wheels as appropriate. In general, assume the maximum tow rating always requires a towing package — and special towing equipment (see "Anatomy of a Towing Package" on page 40) — and the highest numerical axle ratio offered, and as the example shows, maximums can be confusing. You can do your own estimates by starting with the information given and keeping the following generalizations in mind.

Transmission: For the majority of vehicles, automatic transmissions offer the higher tow ratings when they vary by transmission. On heavy-duty (HD) models, the difference may be 1,000 pounds or less, and on lighter-duty vehicles, a manual tranny might rate a 2,000-pound lower tow rating. Exceptions include high-output engines that are available only with manual gearboxes, vehicles where the manual transmission weighs more than the automatic and transmissions in vehicles designed for high performance and not towing.

Axle Ratio: Lower gearing (the numerically higher ratios, e.g. 4.10:1, 4.56:1, as opposed to 3.55:1, 3.73:1), typically produces greater tow ratings because of greater torque multiplication. There is a wide variance in the axle ratio's effect on the tow rating, with some diesel-powered pickups varying only a few hundred pounds. On others, changing from a 3.73:1 to a 4.30:1 sometimes increases the tow rating by 3,500 pounds. In the past, some ratings have increased by a factor greater than three (from 2,000 to 7,100 pounds) simply by using a different axle ratio. Lower gearing will also make your vehicle accelerate quicker up to 50-55 mph. In general, a one-step drop in axle ratio (4.10:1 to 3.73:1) on an HD pickup will drop tow rating and gcwr by a ton.

Lower gearing has an adverse effect on fuel



economy, but it's usually not proportional to the gain in towing ability. Under the best circumstances, the difference between the highest and lowest gear ratios offered (say, 3.42:1 and 4.10:1) results in a 1.5-mpg decrease in non-towing, steady state-highway cruising. In most conditions that change is less than 1 mpg, and if you tow a relatively heavy trailer a lot, there's no question that the lowest gearing is best.

Drive System: Vehicles that drive only two wheels, be they front or rear, generally have higher tow ratings (all other things being equal). Even though modern 4WD and AWD systems are quite efficient, a small amount of parasitic loss uses up energy. More importantly, 4WD systems add weight — easily up to 400 pounds on some HD pickups — and that weight frequently comes off the tow rating. Unless the gcwr and gwvr are higher, a 4WD version will probably tow a few hundred pounds less than its 2WD counterpart.

Towing Package: If you can order a towing package, do so. Not only is it usually required to get the top tow rating, but the contents rarely can be duplicated for the original cost — and it will add to resale value. Frequently you can see the hitch or tow plug, but there are often changes to the wiring system (including up-rated wire and fuses), alternator, battery, cooling system, power steering and lubricants.

Bed Length/Style: If there's a difference, a longbed truck may rate slightly lower in tow capacity — perhaps 150-250 pounds — because the longer bed adds weight. On other cases there is no change because the longer wheelbase is beneficial. Note that the more "styled" beds marketed under a variety of names typically are heavier than conventional slab-sided beds, and that cab-and-chassis figures do not reflect any bed unless otherwise noted. A steel bed for a medium-duty cab-and-chassis could quickly eat up an entire ton of its gcwr.

Single or Dual Rear Wheels: Most people assume that a dually pickup will have a higher tow rating than a single-rear wheel unit, but this is not always so. In many cases the gcwr is limited by factors other than the number of rear wheels and does not change, and in those cases the weight of the wider axle, bigger brakes and two more tires and wheels is subtracted from the gcwr. The dually no doubt provides a more stable towing platform for the heavier trailers, although not always with the highest tow rating. A dualie will have a higher gcwr because the dual-wheel rear axle might have a 10,000-pound gcwr, for example, compared to the single-rear-wheel truck's 6,824-pound gcwr. Gcwr is not always an exact calculation of the tire capacity times the number of tires. A dualie-equipped truck will be better for hauling a heavy slide-in truck camper because of the weight concentrated on the rear axle as compared to the average trailer's hitch weight.

Tires: Wheel sizes continue to grow commensurate with their popularity, with some tow vehicles offering 20-inch-diameter wheels as factory options. However, using a larger wheel and lower-profile tire means a smaller air cushion and lower

tire sidewall, to the extent that tow ratings generally drop whenever the wheel size increases. Be sure to read the fine print on the packaging carefully.

Practical Application

Before purchasing any vehicle for towing, ensure that the equipment required is available for your vehicle. You may find that the new-kid-on-the-block is a very capable tow vehicle, but no one makes a fifth-wheel hitch for it. Also beware of hitch-ball and receiver ratings, as some trucks are rated for heavier loads than any easily found hardware can handle, and therefore may require special-order parts. Also keep in mind that the powertrains used in some vehicles may not be available in each of the 50 states or Canada.

Before making a purchase of a new vehicle, we also suggest that you acquire the manufacturer's comprehensive towing guide, available online or at dealerships. Be sure to read the fine print in the guide because in many cases the maximum rating may apply only to one particular version and be for a fifth-wheel trailer; many larger pickups may have their actual tow rating limited by the hitch and hardware. 🚚



Advanced Brake Controller Technology

For Smooth, Powerful Stops.



TruControl™ Silver



TruControl™ Gold

TruControl™ features

- Automatic Power Adjustment – No Gain Control!
- Smooth, Powerful Stops no matter what speed you're traveling
- Easy Installation
- Factory Direct Sales Made in USA
- 60-day Money Back Guarantee

Call 800-410-6580 Today
and ask which TruControl™
is right for you.



800.410.6580 • www.TruControl.com

'09

TOWING GUIDE



Towing 2009

10 | 2009 **TRAILER LIFE** Towing Guide

Go To: **TRAILER**
FOLLOW THE ROAD TO ADVENTURE
LIFE.com

User Guide

Contents



New models, styling and drivetrains improve towing prowess, comfort and fuel economy

BY CHRIS HEMER

2009 **TRAILER LIFE** Towing Guide | 11

With the fluctuation of fuel prices, you can probably guess the common theme among the crop of 2009 tow vehicles: enhanced fuel economy. While it's true that the Big Three can take years to introduce entirely new vehicles, they have demonstrated their ability to make adjustments to current products in just months to meet market demands. In this case, we're seeing everything from taller rear-axle ratios and new transmissions to aerodynamic improvements and even more hybrid models. But unlike Detroit's mad rush to introduce fuel-sipping econo-cars during the 1970s, these revised tow vehicles don't sacrifice huge chunks of performance in exchange for their fuel-efficient ways. Engineers realize that heavy-duty vehicles like trucks and SUVs still must have adequate tow ratings. After all, that's one of the main reasons we buy them.

When shopping for a new tow vehicle, however, keep in mind that tow ratings can vary significantly on two identically equipped models with different rear-axle-ratio ratings (depending on whether the buyer's priority is fuel economy or maximum towing capability). So, be sure to verify the rear-axle ratio before signing on the dotted line.

Since we don't have room to detail what's new with all makes and models, we're going to focus primarily on popular offerings from the Big

Three, then touch on any new or interesting additions from foreign offerings. Since many features are offered through several lines, we're going to group like vehicles together to avoid repeating the same info.

Ford Motor Company

A redesign of the popular F-150 pickup helps set it apart from the rest of the full-size truck market. Perhaps the most noteworthy highlight is the fully integrated brake control with Trailer Sway Control (TSC) — a first for the F-150 — which synchronizes vehicle and trailer brakes for seamless braking (even with the heaviest loads) to provide added driving control and confidence. This high-tech braking system utilizes a yaw sensor to determine if the vehicle is swaying, and then takes the appropriate countermeasures. These may include applying the brakes to one or more wheels, and/or reducing engine power to bring the vehicle back under control. The popular Ford Explorer and Sport Trac both receive standard TSC as well.

An available Reverse Camera System utilizes a tailgate-mounted camera to produce a visual display in the interior rearview mirror. In addition, when paired with the available advanced Voice-Activated Navigation System, the visual is displayed on the Navigation System's screen.

The 4.6- and 5.4-liter V-8 Triton engines fea-

Ford F-450 Super Duty



Ford F-150



Chevrolet Avalanche



Chevrolet Silverado



ture improved horsepower, and a new six-speed automatic transmission makes its debut in '09. The Flex Fuel-capable 5.4-liter V-8 helps improve fuel economy.

Manual telescoping tow mirrors are available on select models to help with trailer-towing visibility. Heat, turn-signal features and puddle lamps are among the features available with these mirrors.

Three cab styles, four box options and seven trim levels provide potential F-150 buyers with up to 35 different configurations. And if that's not enough, there's the new Platinum Series F-150, the full-boat luxury model that serves as a substitute for the discontinued Lincoln Mark LT.

For families who need the room of an SUV but want something a little more hip and economical, Ford offers the new Flex. Looking like a modern interpretation of a 1950's era Woody (sans the wood), the Flex is available in 2WD or AWD, and its 3.5-liter V-6 engine and six-speed transmission make it capable of towing up to 4,500 pounds when properly equipped. Up to seven passengers can soak up the sun at the same time thanks to the optional Vista roof.

Chrysler Corporation

The biggest news from Dodge is the all-new Ram 1500. In addition to aggressive new looks and power improvements to the available 5.7-liter

Hemi (390 hp and 407 lb-ft of torque), the Ram is now available in a shortbed Crew Cab configuration, which can be outfitted with an optional RamBox cargo-management system. RamBox provides weatherproof, lockable, illuminated and drainable storage compartments integrated into the cargo-box sides. A new chassis features a coil-spring, multi-link rear suspension for improved ride and handling. For the heavy-duty trucks, an automatic transmission is standard on all Hemi-powered 2500 Series models (a manual transmission is no longer available), and the venerable 6.7-liter Cummins diesel engine is now standard on 3500 Series models, as is a limited slip rear axle. Larger brakes front and rear with twin-piston calipers are other noteworthy additions. Hybrid technology finally rolls out on the Chrysler Aspen and Dodge Durango, with a claimed fuel economy savings of 40 percent city, 25 percent highway — with Hemi power, no less.

If you're looking for something a little more modest, consider Dodge's all-new crossover, the Journey. Offered in three trim levels, the Journey can seat up to seven, and can be had in both 2WD and AWD versions. With the available 3.5-liter DOHC V-6 engine and six-speed automatic transmission, the Journey can tow 3,500 pounds with the optional towing package.

Ford Explorer Sport Trac



Ford Flex



Dodge Ram 1500



Dodge Durango



Kia Borrego



Honda Pilot



Toyota Tundra



General Motors

The Chevy Avalanche now comes standard with a six-speed automatic transmission and a 3.08:1 rear-axle ratio on 2WD models with the 5.3-liter V-8. An integrated brake controller is standard, and a heavy-duty trailer package with a 3.42:1 axle ratio is available. Chevy Colorado and GMC Canyon extended and crew cab models are now available with a 5.3-liter V-8, while a new fuel control module on the 2.9-liter engine delivers up to 25 mpg, according to GM. Chevy Silverado and GMC Sierra 1500 series trucks likewise receive six-speed automatic transmissions on 5.3, 6.0- and 6.2-liter engines. The option of an Xtra Fuel Economy (XFE) model is also available, and is claimed to increase fuel efficiency by 1 mpg.

New two-mode hybrid models utilize an Electrically Variable Transmission, a 300-volt energy storage system and cylinder deactivation technology to deliver city/highway fuel economy improvements of 40 percent and 25 percent, respectively. Powered by a 6.0-liter V-8, it can still tow up to 6,100 pounds. As usual, similar changes have been implemented to GM's full-size SUV line, including the Tahoe, Suburban, Yukon and Yukon XL. Six-speed automatic transmissions are standard, and an XFE model is available on the Tahoe and the Yukon. The Tahoe, Yukon and the Cadillac Escalade are available in two-mode hybrid variations.

GM's midsize SUV line, including the GMC Acadia, the Buick Enclave and the Saturn Outlook, now includes the Chevy Traverse. All models are powered by an updated version of GM's 3.6-liter DOHC V-6, which now features direct injection and a 13-hp boost over last year's engine. You'll notice in the accompanying guide that the Traverse has a 5,200-pound tow rating, while its siblings still carry last year's 4,500-pound rating. At the time of this writing, GM expected to upgrade the other models to the

5,200-pound rating as well (except the Buick Enclave). Be sure to check with your dealer.

The Others

The Honda Pilot is all-new for 2009, and is longer, taller and wider than the previous model. Up to eight passengers can fit in the three rows, and it's available in 2WD and 4WD. The standard 3.5-liter iVTEC V-6 features a revised version of Honda's Variable Cylinder Management, which allows the engine to run in six-cylinder, four-cylinder and three-cylinder modes for greater fuel efficiency. An integrated hitch receiver and hill start assist are among the many features RV owners will find useful.

Kia has introduced a full-size SUV called the Borrego. Available in 2WD or 4WD, this full-size SUV means business, with a standard 276-hp V-6, or an available 4.6-liter, DOHC V-8. The latter produces 337 hp and bestows the Borrego with a tow rating of up to 7,500 pounds.

At press time, not much is known about Toyota's new Venza, except that it is a crossover that fills the gap between the RAV4 and the popular Highlander. Power comes from a standard 2.7-liter four cylinder, or an optional 3.5-liter V-6 producing 268 hp. Venza is available in 2WD or AWD, and all models feature a six-speed automatic transmission. 📞

F-250/F-350/F-450 Super Duty, Fifth-Wheel Towing, Automatic Transmission		
F-250/F-350 Regular Cab SRW 2WD	5.4L V-8	10,200 (e)
F-250/F-350 Regular Cab SRW 2WD	5.4L V-8	12,200 (f)
F-250/F-350 Regular Cab SRW 2WD	6.8L V-10	15,000 (f)
F-250/F-350 Regular Cab SRW 2WD	6.8L V-10	16,800 (g)
F-250/F-350 Regular Cab SRW 2WD	6.4L V-8 TD	16,300 (d/e)
F-250/F-350 Regular Cab SRW 4WD	5.4L V-8	9,800 (e)
F-250/F-350 Regular Cab SRW 4WD	5.4L V-8	11,800 (f)
F-250/F-350 Regular Cab SRW 4WD	6.8L V-10	14,600 (f)
F-250/F-350 Regular Cab SRW 4WD	6.8L V-10	16,500 (g)
F-250/F-350 Regular Cab SRW 4WD	6.4L V-8 TD	15,800 (e)
F-350 Regular Cab DRW 2WD	5.4L V-8	12,200 (f)

F-350 Crew Cab DRW 2WD	6.8L V-10	16,000 (g)
F-350 Crew Cab DRW 2WD	6.4L V-8 TD	15,700 (e/f)
F-350 Crew Cab DRW 2WD	6.4L V-8 TD	18,200 (g,t)
F-350 Crew Cab DRW 4WD	6.8L V-10	14,000 (f)
F-350 Crew Cab DRW 4WD	6.8L V-10	15,500 (g)
F-350 Crew Cab DRW 4WD	6.4L V-8 TD	15,200 (e/f)
F-350 Crew Cab DRW 4WD	6.4L V-8 TD	17,700 (g,t)
F-450 Crew Cab DRW 2WD	6.4L V-8 TD	24,500 (g,t)
F-450 Crew Cab DRW 4WD	6.4L V-8 TD	24,200 (g,t)

F-250/F-350/F-450 Super Duty, Fifth-Wheel Towing, Manual Transmission		
F-250/F-350 Reg. Cab SRW 2WD	5.4L V-8	9,200 (e)

How to Use This Guide

Under each vehicle brand, you will find three headings: Vehicle, Engine and Tow Limit (lb). The vehicle heading describes the vehicle model and/or configuration, and indicates whether the vehicle is 2WD (front or rear), 4WD or All Wheel Drive (AWD). The engine heading shows the engine size expressed in liters, followed by the configuration (I = Inline, V = V engine as in V-6 or V-8) and the number of cylinders. Under tow limit, you will find the manufacturer's stated maximum tow capacity for that vehicle. In many instances, you may note a letter(s) and/or symbol(s) after the model or tow rating, which indicates a footnote listing specific requirements for that rating, such as a certain gear ratio. When letters or symbols are separated by a comma, this indicates that more than one footnote applies; when separated by a forward slash (/) either/or can apply.

A slash may also be used to separate two different models, if the ratings differ depending on how the vehicle is equipped. In these instances, ratings relative to the model or its equipment will be listed in respective order under the tow limit heading. Example:

Vehicle	Engine	Tow Limit (lb)
Trailblazer/Envoy 2WD	4.2L I-6	5,400/5,300(e)

Moreover, the ratings are listed in a similar manner to the manufacturers. For example, Ford Motor Company lists conventional and fifth-wheel tow ratings separately, while Dodge, GM and Toyota list them together. Likewise, Ford lists automatic and manual-transmission-equipped models under separate headings, while other manufacturers list

them under the same headings with a separate column that denotes transmission type.

Footnotes are listed immediately under each brand or vehicle family, and consist of various keys for gear ratios as well as abbreviations for vehicle configurations (LB = Longbed, CC = Crew Cab, etc.), notes about how different trim levels or options may affect towing capacity, etc. If there is no footnote, then there is only one vehicle configuration capable of towing that amount.

We've also included pertinent factory notes where applicable about each vehicle or family of vehicles, but due to space considerations, we cannot possibly list all of them. When considering a certain vehicle for purchase based on its tow rating, make sure to consult with the dealer and/or manufacturer's towing guide to get specifics on what that tow rating is based upon. For example, many tow ratings are based on an unloaded vehicle with one occupant; if you normally travel with your family and equipment, you must deduct passenger/equipment weight accordingly to arrive at that vehicle's actual towing capacity in your application. Most trailer weights are based on the assumption that you will be using a weight-distributing hitch (and rightfully so), and have drastically reduced ratings for the same application using a weight-carrying hitch.

Finally, remember that every effort has been made to ensure the accuracy of this guide, but many of the ratings contained in it were considered "preliminary" by the manufacturer at the time of this writing (which is before "official" ratings have been released in many cases). Most of the time, the numbers don't change when the official ratings are released but, in some instances, they do. Perhaps more importantly, the ratings don't usually change significantly enough to affect your purchase decision. 🚛

Trailer Life 2009 Tow Ratings Guide

COMPILED BY CHRIS HEMER

ACURA

Vehicle	Engine	Tow Limit (lb)
MDX	3.7L V-6	5,000

AUDI

Q7	3.6L V-6	5,500
Q7	3.6L V-6	6,600 (t)
Q7	4.2L V-8	5,500
Q7	4.2L V-8	6,600 (t)

BMW

X3 3.0si	3.0L I-6	3,500
X5 3.0si	3.0L I-6	6,000
X5 4.8Li	4.8L V-8	6,000
X6	3.0L I-6	6,000
X6	4.4L V-8	6,000

BUICK

Enclave FWD	3.6L V-6	2,000
Enclave FWD	3.6L V-6	4,500 (t)

CADILLAC

Escalade 2WD	6.2L V-8	8,300
Escalade AWD	6.2L V-8	8,100
Escalade ESV 2WD	6.2L V-8	7,600
Escalade ESV AWD	6.2L V-8	7,800
Escalade EXT AWD	6.2L V-8	7,500
Escalade Two Mode Hybrid 2WD	6.0L V-8	5,800
Escalade Two Mode Hybrid 4WD	6.0L V-8	5,600
SRX	All	2,000
SRX	All	4,250 (t)

CHEVROLET/GMC

Avalanche 1500 2WD	5.3L V-8	5,100 (b*)
Avalanche 1500 2WD	5.3L V-8	5,600 (e*)
Avalanche 1500 2WD	5.3L V-8	8,100 (e,p*)
Avalanche 1500 2WD	5.3L V-8	5,000 (b)
Avalanche 1500 2WD	5.3L V-8	5,500 (e)
Avalanche 1500 2WD	5.3L V-8	8,000 (e)
Avalanche 1500 2WD	6.0L V-8	8,100
Avalanche 1500 4WD	5.3L V-8	5,400 (e*)
Avalanche 1500 4WD	5.3L V-8	7,800 (e,p*)
Avalanche 1500 4WD	5.3L V-8	5,500 (e)
Avalanche 1500 4WD	5.3L V-8	7,900 (e,p)
Avalanche 1500 4WD	6.0L V-8	7,700 (e)

* = Flex Fuel model

Traverse/Acadia FWD	3.6L V-6	2,000
Traverse/Acadia FWD	3.6L V-6	5,200 (t)/4,500 (t)
Traverse/Acadia AWD	3.6L V-6	2,000
Traverse/Acadia AWD	3.6L V-6	5,200 (t)/4,500 (t)
Colorado/ Canyon Reg Cab 2WD	2.9L I-4	3,400 (a,g)
Colorado/ Canyon Reg Cab 2WD	2.9L I-4	2,400 (m,g)
Colorado/ Canyon Reg Cab 2WD	3.7L I-5	4,000 (a,g)
Colorado/ Canyon Ext Cab 2WD	2.9L I-4	3,200 (a,g)
Colorado/ Canyon Ext Cab 2WD	2.9L I-4	2,200 (m,g)
Colorado/ Canyon Ext Cab 2WD	3.7L I-5	5,500 (a,g)
Colorado/ Canyon Ext Cab 2WD	5.3L V-8	6,000 (a,e/g)
Colorado/ Canyon Ext Cab 2WD	5.3L V-8	4,000 (a,e*)
Colorado/ Canyon CC 2WD	2.9L I-4	3,000 (a,g)
Colorado/ Canyon CC 2WD	2.9L I-4	2,100 (m,g)
Colorado/ Canyon CC 2WD	3.7L I-5	5,500 (a,g)
Colorado/ Canyon CC 2WD	5.3L V-8	6,000 (a,e/g)
Colorado/ Canyon Reg Cab 4WD	2.9L I-4	3,100 (a,g)
Colorado/ Canyon Reg Cab 4WD	2.9L I-4	2,100 (m,g)
Colorado/ Canyon Reg Cab 4WD	3.7L I-5	4,000 (a,g)
Colorado/ Canyon Ext Cab 4WD	2.9L I-4	2,900 (a,g)
Colorado/ Canyon Ext Cab 4WD	3.7L I-5	5,500 (a,g)
Colorado/ Canyon Ext Cab 4WD	5.3L V-8	6,000 (a,e/f)
Colorado/ Canyon Ext Cab 4WD	5.3L V-8	3,800 (a,e*)
Colorado/ Canyon CC 4WD	3.7L I-5	5,500 (a,g)
Colorado/ Canyon CC 4WD	5.3L V-8	6,000 (a,e/f)

* With ZQ8 Sport Suspension

Equinox	All	3,500
Express/Savana 1500 SWB CV 2WD	4.3L V-6	4,400
Express/Savana 1500 SWB CV 2WD	5.3L V-8	6,700 (e/g)
Express/Savana 1500 SWB CV AWD	5.3L V-8	6,500
Express/Savana 1500 SWB PV 2WD	5.3L V-8	6,200
Express/Savana 1500 SWB PV AWD	5.3L V-8	6,000
Express/Savana 2500 SWB CV 2WD	4.8L V-8	6,400 (g)
Express/Savana 2500 SWB CV 2WD	4.8L V-8	7,400 (i)
Express/Savana 2500 SWB CV 2WD	6.0L V-8	8,400 (g)
Express/Savana 2500 SWB CV 2WD	6.0L V-8	10,000 (i)
Express/Savana 2500 SWB PV 2WD	6.0L V-8	7,600 (g)
Express/Savana 2500 SWB PV 2WD	6.0L V-8	10,000 (i)
Express/Savana 2500 LWB CV 2WD	4.8L V-8	6,200 (g)
Express/Savana 2500 LWB CV 2WD	4.8L V-8	7,200 (i)
Express/Savana 2500 LWB CV 2WD	6.0L V-8	8,200 (g)
Express/Savana 2500 LWB CV 2WD	6.0L V-8	10,000 (i)
Express/Savana 3500 SWB CV 2WD	4.8L V-8	6,400 (g)
Express/Savana 3500 SWB CV 2WD	4.8L V-8	9,400 (i)
Express/Savana 3500 SWB CV 2WD	6.0L V-8	8,400 (g)
Express/Savana 3500 SWB CV 2WD	6.0L V-8	10,000 (i)
Express/Savana 3500 SWB PV 2WD	6.0L V-8	7,600 (g)

Express/Savana 3500 LWB CV 2WD	4.8L V-8	6,100 (g)
Express/Savana 3500 LWB CV 2WD	4.8L V-8	7,100 (i)
Express/Savana 3500 LWB CV 2WD	6.0L V-8	8,200 (g)
Express/Savana 3500 LWB CV 2WD	6.0L V-8	10,000 (i)
Express/Savana 3500 LWB PV 2WD	6.0L V-8	7,300 (g)

Silverado/Sierra 1500 Reg Cab, Std. Bed

1500 Reg Cab Std. Bed 2WD	4.3L V-6	4,800 (d)
1500 Reg Cab Std. Bed 2WD	4.3L V-6	5,300 (g)
1500 Reg Cab Std. Bed 2WD	4.8L V-8	5,200 (d)
1500 Reg Cab Std. Bed 2WD	4.8L V-8	7,200 (g)
1500 Reg Cab Std. Bed 2WD	5.3L V-8	7,200 (a4,e)
1500 Reg Cab Std. Bed 2WD	5.3L V-8	8,200 (a4,g)
1500 Reg Cab Std. Bed 2WD	5.3L V-8	6,600 (a6,e*)
1500 Reg Cab Std. Bed 2WD	5.3L V-8	6,700 (a6,e)
1500 Reg Cab Std. Bed 2WD	5.3L V-8	9,100 (a6,e,p*)
1500 Reg Cab Std. Bed 2WD	5.3L V-8	9,200 (a6,e,p)
1500 Reg Cab Std. Bed 4WD	4.3L V-6	5,100 (g)
1500 Reg Cab Std. Bed 4WD	4.8L V-8	6,000 (e)
1500 Reg Cab Std. Bed 4WD	5.3L V-8	6,400 (e)
1500 Reg Cab Std. Bed 4WD	5.3L V-8	8,900 (e,p)
1500 Reg Cab Std. Bed 4WD	5.3L V-8	7,900 (g)
1500 Reg Cab Std. Bed 4WD	5.3L V-8	8,900 (i)

*Flex Fuel model

Silverado/Sierra 1500 Ext Cab, Std. Bed

1500 Ext Cab Std. Bed 2WD	4.3L V-6	4,400 (d)
1500 Ext Cab Std. Bed 2WD	4.3L V-6	4,900 (g)
1500 Ext Cab Std. Bed 2WD	4.8L V-8	4,700 (d)
1500 Ext Cab Std. Bed 2WD	4.8L V-8	6,700 (g)
1500 Ext Cab Std. Bed 2WD	5.3L V-8	6,700 (a4,e)
1500 Ext Cab Std. Bed 2WD	5.3L V-8	7,700 (a4,g)
1500 Ext Cab Std. Bed 2WD	5.3L V-8	6,200 (a6,e)
1500 Ext Cab Std. Bed 2WD	5.3L V-8	9,700 (a6,e,p)
1500 Ext Cab Std. Bed 2WD	6.0L V-8	6,700 (e)
1500 Ext Cab Std. Bed 2WD	6.0L V-8	9,700 (e,p)
1500 Ext Cab Std. Bed 2WD	6.0L V-8	10,700 (g,t)
1500 Ext Cab Std. Bed 4WD	4.8L V-8	5,500 (e)
1500 Ext Cab Std. Bed 4WD	5.3L V-8	5,900 (e)
1500 Ext Cab Std. Bed 4WD	5.3L V-8	9,400 (e,p)
1500 Ext Cab Std. Bed 4WD	5.3L V-8	7,500 (g)
1500 Ext Cab Std. Bed 4WD	5.3L V-8	8,500 (i)
1500 Ext Cab Std. Bed 4WD	6.0L V-8	6,400 (e)
1500 Ext Cab Std. Bed 4WD	6.0L V-8	9,400 (e,p)
1500 Ext Cab Std. Bed 4WD	6.0L V-8	10,400 (g,t)

Silverado/Sierra 1500 Ext Cab, Shortbed

1500 Ext Cab Shortbed 2WD	4.3L V-6	4,400 (d)
1500 Ext Cab Shortbed 2WD	4.3L V-6	4,900 (g)
1500 Ext Cab Shortbed 2WD	4.8L V-8	5,800 (e)
1500 Ext Cab Shortbed 2WD	4.8L V-8	6,800 (g)
1500 Ext Cab Shortbed 2WD	5.3L V-8	6,800 (e)
1500 Ext Cab Shortbed 2WD	5.3L V-8	7,800 (g)
1500 Ext Cab Shortbed 2WD	6.0L V-8	6,700 (e)
1500 Ext Cab Shortbed 2WD	6.0L V-8	9,700 (e,p)
1500 Ext Cab Shortbed 4WD	4.8L V-8	5,500 (e)

1500 Ext Cab Shortbed 4WD	4.8L V-8	8,500 (i)
1500 Ext Cab Shortbed 4WD	5.3L V-8	7,500 (g)
1500 Ext Cab Shortbed 4WD	5.3L V-8	8,500 (i)
1500 Ext Cab Shortbed 4WD	6.0L V-8	6,400 (e)
1500 Ext Cab Shortbed 4WD	6.0L V-8	9,400 (e,p)

Silverado/Sierra 1500 CC, Shortbed

1500 CC Shortbed 2WD	4.8L V-8	4,700 (d)
1500 CC Shortbed 2WD	4.8L V-8	6,700 (g)
1500 CC Shortbed 2WD	5.3L V-8	6,100 (e)
1500 CC Shortbed 2WD	5.3L V-8	9,600 (e,p)
1500 CC Shortbed 2WD	6.0L V-8	6,600 (e)
1500 CC Shortbed 2WD	6.2L V-8	6,600 (e)
1500 CC Shortbed 2WD	6.0L V-8	9,600 (e,p)
1500 CC Shortbed 2WD	6.2L V-8	9,600 (e,p)
1500 CC Shortbed 2WD	6.0L V-8	10,600 (g,t)
1500 CC Shortbed 2WD	6.2L V-8	10,600 (g,t)
1500 CC Shortbed 4WD	4.8L V-8	5,400 (e)
1500 CC Shortbed 4WD	5.3L V-8	6,000 (e)
1500 CC Shortbed 4WD	5.3L V-8	9,500 (e,p)
1500 CC Shortbed 4WD	6.0L V-8	6,300 (e)
1500 CC Shortbed 4WD	6.2L V-8	6,300 (e)
1500 CC Shortbed 4WD	6.0L V-8	9,300 (e,p)
1500 CC Shortbed 4WD	6.2L V-8	9,300 (e,p)
1500 CC Shortbed 4WD	6.0L V-8	10,400 (g,t)

Manufacturer's Note: Travel trailer ratings are shown; fifth-wheel ratings may be considerably less (up to 1,000 lb).

Sierra Denali CC Shortbed, 1500 2WD and AWD

Sierra Denali CC Shortbed 2WD	5.3L V-8	6,100
Sierra Denali CC Shortbed 2WD	5.3L V-8	9,600 (p)
Sierra Denali CC Shortbed 2WD	6.2L V-8	6,600
Sierra Denali CC Shortbed 2WD	6.2L V-8	9,600 (p)
Sierra Denali CC Shortbed AWD	5.3L V-8	6,000
Sierra Denali CC Shortbed AWD	5.3L V-8	9,500 (p)
Sierra Denali CC Shortbed AWD	6.2L V-8	6,300
Sierra Denali CC Shortbed AWD	6.2L V-8	9,300 (p)

Manufacturer's Note: This model is neither designed nor intended to tow a fifth-wheel or gooseneck trailer.

Silverado/Sierra 1500 Reg Cab LB

1500 Reg Cab LB 2WD	4.3L V-6	4,700 (d)
1500 Reg Cab LB 2WD	4.3L V-6	5,200 (g)
1500 Reg Cab LB 2WD	4.8L V-8	5,100 (d)
1500 Reg Cab LB 2WD	4.8L V-8	7,100 (g)
1500 Reg Cab LB 2WD	5.3L V-8	7,000 (a4,e)
1500 Reg Cab LB 2WD	5.3L V-8	8,000 (a4,e)
1500 Reg Cab LB 2WD	5.3L V-8	6,500 (a6,e)
1500 Reg Cab LB 2WD	5.3L V-8	10,000 (a6,e,p)
1500 Reg Cab LB 4WD	4.3L V-6	4,900 (g)
1500 Reg Cab LB 4WD	4.8L V-8	5,800 (e)
1500 Reg Cab LB 4WD	5.3L V-8	6,300 (e)
1500 Reg Cab LB 4WD	5.3L V-8	9,800 (e,p)
1500 Reg Cab LB 4WD	5.3L V-8	7,900 (g)
1500 Reg Cab LB 4WD	5.3L V-8	8,900 (i)

Silverado/Sierra 1500 Ext Cab LB

1500 Ext Cab LB 2WD	5.3L V-8	7,600 (a4,g)
1500 Ext Cab LB 2WD	5.3L V-8	6,000 (a6,e)
1500 Ext Cab LB 2WD	5.3L V-8	9,500 (a6,e,p)
1500 Ext Cab LB 4WD	5.3L V-8	5,700 (e)
1500 Ext Cab LB 4WD	5.3L V-8	9,200 (e,p)
1500 Ext Cab LB 4WD	5.3L V-8	7,600 (g*)
1500 Ext Cab LB 4WD	5.3L V-8	7,300 (g)

* Flex Fuel model

Silverado/Sierra Two-Mode Hybrid

Two-Mode Hybrid 2WD	6.0L V-8	6,100 (b)
Two-Mode Hybrid 4WD	6.0L V-8	5,900 (b)

Silverado/Sierra 2500 Ext Cab Std. Bed

2500 Ext Cab Std. Bed 2WD	6.0L V-8	10,200 (g)
2500 Ext Cab Std. Bed 2WD	6.0L V-8	12,700 (i)
2500 Ext Cab Std. Bed 2WD	6.6L V-8 TD	15,500 (g)
2500 Ext Cab Std. Bed 4WD	6.0L V-8	9,900 (g)
2500 Ext Cab Std. Bed 4WD	6.0L V-8	12,400 (i)
2500 Ext Cab Std. Bed 4WD	6.6L V-8 TD	14,500 (g)

Silverado/Sierra 2500 CC Std. Bed

2500 CC Std. Bed 2WD	6.0L V-8	10,000 (g)
2500 CC Std. Bed 2WD	6.0L V-8	12,500 (i)
2500 CC Std. Bed 2WD	6.6L V-8 TD	15,300 (g)
2500 CC Std. Bed 4WD	6.0L V-8	9,800 (g)
2500 CC Std. Bed 4WD	6.0L V-8	12,300 (i)
2500 CC Std. Bed 4WD	6.6L V-8 TD	13,900 (g)

Silverado/Sierra 2500 Reg Cab LB

2500 Reg Cab LB 2WD	6.0L V-8	10,500 (g)
2500 Reg Cab LB 2WD	6.0L V-8	13,000 (i)
2500 Reg Cab LB 2WD	6.6L V-8 TD	15,800 (g)
2500 Reg Cab LB 4WD	6.0L V-8	10,200 (g)
2500 Reg Cab LB 4WD	6.0L V-8	12,700 (i)
2500 Reg Cab LB 4WD	6.6L V-8 TD	15,500 (g)

Silverado/Sierra 2500 Ext Cab LB

2500 Ext Cab LB 2WD	6.0L V-8	10,000 (g)
2500 Ext Cab LB 2WD	6.0L V-8	12,500 (i)
2500 Ext Cab LB 2WD	6.6L V-8 TD	15,300 (g)
2500 Ext Cab LB 4WD	6.0L V-8	9,800 (g)
2500 Ext Cab LB 4WD	6.0L V-8	12,300 (i)
2500 Ext Cab LB 4WD	6.6L V-8 TD	13,800 (g)

Silverado/Sierra 2500 CC LB

2500 CC LB 2WD	6.0L V-8	9,900 (g)
2500 CC LB 2WD	6.0L V-8	12,400 (i)
2500 CC LB 2WD	6.6L V-8 TD	14,500 (g)
2500 CC LB 4WD	6.0L V-8	9,600 (g)
2500 CC LB 4WD	6.0L V-8	12,100 (i)
2500 CC LB 4WD	6.6L V-8 TD	13,000 (g)

Silverado/Sierra 3500 Reg Cab

3500 Reg Cab SRW 2WD	6.0L V-8	10,300 (g)
3500 Reg Cab SRW 2WD	6.0L V-8	12,800 (i)
3500 Reg Cab SRW 2WD	6.6L V-8 TD	15,800 (g)
3500 Reg Cab DRW 2WD	6.0L V-8	10,000 (g)
3500 Reg Cab DRW 2WD	6.0L V-8	12,500 (i)
3500 Reg Cab DRW 2WD	6.6L V-8 TD	16,800 (g)
3500 Reg Cab SRW 4WD	6.0L V-8	10,000 (g)
3500 Reg Cab SRW 4WD	6.0L V-8	12,500 (i)
3500 Reg Cab SRW 4WD	6.6L V-8 TD	15,400 (g)
3500 Reg Cab DRW 4WD	6.0L V-8	9,700 (g)
3500 Reg Cab DRW 4WD	6.0L V-8	12,200 (i)
3500 Reg Cab DRW 4WD	6.6L V-8 TD	16,500 (g)

Silverado/Sierra 3500 Ext Cab

3500 Ext Cab SRW 2WD	6.0L V-8	9,900 (g)
3500 Ext Cab SRW 2WD	6.0L V-8	12,400 (i)
3500 Ext Cab SRW 2WD	6.6L V-8 TD	15,400 (g)
3500 Ext Cab DRW 2WD	6.0L V-8	9,500 (g)
3500 Ext Cab DRW 2WD	6.0L V-8	12,000 (i)
3500 Ext Cab DRW 2WD	6.6L V-8 TD	16,300 (g)
3500 Ext Cab SRW 4WD	6.0L V-8	9,600 (g)
3500 Ext Cab SRW 4WD	6.0L V-8	12,100 (i)
3500 Ext Cab SRW 4WD	6.6L V-8 TD	14,900 (g)
3500 Ext Cab DRW 4WD	6.0L V-8	9,200 (g)
3500 Ext Cab DRW 4WD	6.0L V-8	11,700 (i)
3500 Ext Cab DRW 4WD	6.6L V-8 TD	16,100 (g)

Silverado/Sierra 3500 CC

3500 CC SRW 2WD	6.0L V-8	9,700 (g)
3500 CC SRW 2WD	6.0L V-8	12,200 (i)
3500 CC SRW 2WD	6.6L V-8 TD	15,100 (g)
3500 CC DRW 2WD	6.0L V-8	9,300 (g)
3500 CC DRW 2WD	6.0L V-8	11,800 (i)
3500 CC DRW 2WD	6.6L V-8 TD	16,200 (g)
3500 CC SRW 4WD	6.0L V-8	9,400 (g)
3500 CC SRW 4WD	6.0L V-8	11,900 (i)
3500 CC SRW 4WD	6.6L V-8 TD	14,800 (g)
3500 CC DRW 4WD	6.0L V-8	9,100 (g)
3500 CC DRW 4WD	6.0L V-8	11,600 (i)
3500 CC DRW 4WD	6.6L V-8 TD	15,900 (g)

Chevy Tahoe and Suburban, GMC Yukon, Yukon XL, Yukon and Yukon XL Denali 1500 Series

Tahoe/Yukon 2WD	4.8L V-8	4,500 (d)
Tahoe/Yukon 2WD	4.8L V-8	4,800 (g)
Tahoe/Yukon 2WD	5.3L V-8	5,400 (b)
Tahoe/Yukon 2WD	5.3L V-8	5,900 (e)
Tahoe/Yukon 2WD	5.3L V-8	8,400 (e,p)
Tahoe/Yukon 2WD	6.2L V-8	8,500 (e)
Tahoe/Yukon Two-Mode Hybrid, 2WD	6.0L V-8	6,200
Tahoe/Yukon 4WD	5.3L V-8	5,700
Tahoe/Yukon 4WD	5.3L V-8	8,200 (p)
Tahoe/Yukon 4WD	6.2L V-8	8,100
Tahoe/Yukon Two-Mode Hybrid, 4WD	6.0L V-8	6,000

Suburban/Yukon XL 2WD	5.3L V-8	5,100 (b)
Suburban/Yukon XL 2WD	5.3L V-8	5,600 (e)
Suburban/Yukon XL 2WD	5.3L V-8	8,100 (e,p)
Suburban/Yukon XL 2WD	6.0L V-8	8,100
Suburban/Yukon XL 4WD	5.3L V-8	5,400 (e)
Suburban/Yukon XL 4WD	5.3L V-8	7,900 (e,p)
Suburban/Yukon XL 4WD	6.0L V-8	7,900
Yukon Denali 2WD	6.2L V-8	8,100
Yukon Denali AWD	6.2L V-8	8,100
Yukon XL Denali 2WD	6.2L V-8	7,600
Yukon XL Denali AWD	6.2L V-8	7,900

Chevy Suburban, GMC Yukon XL 2500

2500 Long Wheelbase 2WD	6.0L V-8	9,600
2500 Long Wheelbase 4WD	6.0L V-8	9,300

Chevy Trailblazer/GMC Envoy/Envoy Denali

Trailblazer/ Envoy 2WD	4.2L I-6	5,400/5,300 (e)
Trailblazer/ Envoy 2WD	4.2L I-6	5,900/5,800 (g)
Trailblazer/ Envoy 2WD	4.2L I-6	6,400 (j)/6,300 (i)
Trailblazer/ Envoy 2WD	5.3L V-8	6,300 (e)/6,100 (e)
Trailblazer/ Envoy 2WD	5.3L V-8	6,800 (g)/6,600 (g)
Trailblazer/ Envoy 4WD	4.2L I-6	5,200 (e)
Trailblazer/ Envoy 4WD	4.2L I-6	5,700 (g)
Trailblazer/ Envoy 4WD	4.2L I-6	6,200 (i)
Trailblazer/ Envoy 4WD	5.3L V-8	6,100 (e)/6,000 (e)
Trailblazer/ Envoy 4WD	5.3L V-8	6,600 (g)/6,500 (g)
Trailblazer SS 2WD	6.0L V-8	6,800 (i)
Trailblazer SS AWD	6.0L V-8	6,600 (i)

Key to GM Section

<i>a</i> = Automatic Transmission	<i>AWD</i> = All Wheel Drive
<i>a4</i> = Automatic Transmission, four speed	<i>CC</i> = Crew Cab
<i>a5</i> = Automatic Transmission, five speed	<i>LB</i> = 8-foot bed
<i>a6</i> = Auto Transmission, six speed	<i>Shortbed</i> = 5-foot 9-inch bed
<i>m</i> = Manual Transmission	<i>Std. Bed</i> = 6 1/2-foot bed
<i>b</i> = 3.08:1 axle ratio	<i>SWB</i> = Short Wheelbase
<i>d</i> = 3.23:1 axle ratio	<i>LWB</i> = Long Wheelbase
<i>e</i> = 3.42:1 axle ratio	<i>DRW</i> = Dual Rear Wheels
<i>g</i> = 3.73:1 axle ratio	<i>SRW</i> = Single Rear Wheel
<i>i</i> = 4:10:1 axle ratio	<i>CV</i> = Cargo Van
<i>p</i> = Cooling-package required	<i>PV</i> = Passenger Van
	<i>TD</i> = Turbodiesel
	<i>t</i> = Tow package required

CHRYSLER/DODGE

Chrysler 300	3.5L V-6	2,000
Chrysler 300	5.7L V-8	2,000
Aspen Limited 2WD	4.7L V-8	4,400 (c)
Aspen Limited 2WD	4.7L V-8	5,900 (f)
Aspen Limited 2WD	5.7L V-8	5,900 (c)
Aspen Limited 2WD	5.7L V-8	8,900 (h)
Aspen Limited 4WD	4.7L V-8	5,750 (f)
Aspen Limited 4WD	5.7L V-8	7,200 (f)
Aspen Limited 4WD	5.7L V-8	8,700 (h)
Aspen Limited 4WD hybrid	5.7L V-8	6,000

Caliber	2.4L I-4	2,000 (t)
Charger	3.5L V-6	2,000
Charger	5.7L V-8	2,000
Grand Caravan	3.3L V-6	2,000 (t)
Grand Caravan	3.8L V-6	3,600 (t)
Grand Caravan	4.0L V-6	3,600 (t)
Journey	3.5L V-6	3,500 (t)
Town and Country	3.3L V-6	2,000 (t)
Town and Country	3.8L V-6	3,600 (t)
Town and Country	4.0L V-6	3,600 (t)

Dodge Dakota

Dakota Ext Cab Shortbed 2WD	3.7L V-6	3,350 (m6,c)
Dakota Ext Cab Shortbed 2WD	3.7L V-6	4,700 (a4,f)
Dakota Ext Cab Shortbed 2WD	3.7L V-6	5,000 (a4,h)
Dakota Ext Cab Shortbed 2WD	4.7L V-8	6,000 (a5,f)
Dakota Ext Cab Shortbed 2WD	4.7L V-8	7,200 (a5,h)
Dakota Ext Cab Shortbed 4WD	3.7L V-6	3,950 (m6,f)
Dakota Ext Cab Shortbed 4WD	3.7L V-6	4,800 (a4,h)
Dakota Ext Cab Shortbed 4WD	4.7L V-8	5,800 (a5,f)
Dakota Ext Cab Shortbed 4WD	4.7L V-8	7,000 (a5,g)
Dakota CC Shortbed 2WD	3.7L V-6	3,200 (m6,c)
Dakota CC Shortbed 2WD	3.7L V-6	4,500 (a4,f)
Dakota CC Shortbed 2WD	3.7L V-6	4,800 (a4,h)
Dakota CC Shortbed 2WD	4.7L V-8	5,850 (a5,f)
Dakota CC Shortbed 2WD	4.7L V-8	7,050 (a5,h)
Dakota CC Shortbed 4WD	3.7L V-8	3,800 (m6,f)
Dakota CC Shortbed 4WD	3.7L V-8	4,600 (a4,h)
Dakota CC Shortbed 4WD	4.7L V-8	5,650 (a5,f)
Dakota CC Shortbed 4WD	4.7L V-8	6,850 (a5,h)

Manufacturer's Note: V-6 weight ratings shown are for ST trim levels, V-8 ratings are for SXT trim levels. Actual ratings may differ slightly between V-6 ST and SXT, depending on model (Extended Cab or Crew Cab).

Dodge Durango

Durango 2WD	3.7L V-6	3,800 (a4,h)
Durango 2WD	4.7L V-8	4,550 (a5,c)
Durango 2WD	4.7L V-8	6,000 (a5,f)
Durango 2WD	5.7L V-8	5,950 (a5,c)
Durango 2WD	5.7L V-8	8,950 (a5,h)
Durango 4WD	4.7L V-8	5,900 (a5,f)
Durango 4WD	5.7L V-8	7,250 (a5,f)
Durango 4WD	5.7L V-8	8,750 (a5,h)
Durango 4WD hybrid	5.7L V-8	6,000

Manufacturer's Note: Weights shown are the highest available for a given model/engine. Weights can vary depending on the model and equipment chosen.

Ram 1500 Regular Cab Shortbed

1500 Reg Cab SB 2WD	3.7L V-6	3,300 (m,h)
1500 Reg Cab SB 2WD	3.7L V-6	3,800 (a4,f/h)
1500 Reg Cab SB 2WD	4.7L V-8	6,650 (a5,f)
1500 Reg Cab SB 2WD	4.7L V-8	7,650 (a5,h)
1500 Reg Cab SB 2WD	5.7L V-8	6,100 (a5,c)
1500 Reg Cab SB 2WD	5.7L V-8	8,100 (a5,f)
1500 Reg Cab SB 2WD	5.7L V-8	9,100 (a5,h)

1500 Reg Cab SB 4WD	4.7L V-8	6,400 (a5,f*)
1500 Reg Cab SB 4WD	4.7L V-8	7,400 (a5,h*)
1500 Reg Cab SB 4WD	5.7L V-8	7,900 (a5,f*)
1500 Reg Cab SB 4WD	5.7L V-8	8,900 (a5,h*)

Ram 1500 Regular Cab Longbed

1500 Reg Cab LB 2WD	3.7L V-6	3,100 (m,h)
1500 Reg Cab LB 2WD	3.7L V-6	3,650 (a4,h)
1500 Reg Cab LB 2WD	4.7L V-8	6,500 (a5,f)
1500 Reg Cab LB 2WD	4.7L V-8	7,500 (a5,h)
1500 Reg Cab LB 2WD	5.7L V-8	6,000 (a5,c)
1500 Reg Cab LB 2WD	5.7L V-8	8,000 (a5,f)
1500 Reg Cab LB 2WD	5.7L V-8	9,000 (a5,h)
1500 Reg Cab LB 4WD	4.7L V-8	6,350 (a5,f*)
1500 Reg Cab LB 4WD	4.7L V-8	7,250 (a5,h*)
1500 Reg Cab LB 4WD	5.7L V-8	7,750 (a5,f*)
1500 Reg Cab LB 4WD	5.7L V-8	8,750 (a5,h*)

*Ratings for LT265 tires. LT275 tires rated 50-100 lb less depending on model.

Ram 1500 Quad Cab

Ram 1500 Quad Cab 2WD	3.7L V-6	2,950 (m,h)
Ram 1500 Quad Cab 2WD	3.7L V-6	3,450 (a4,h)
Ram 1500 Quad Cab 2WD	4.7L V-8	6,350 (a5,f)
Ram 1500 Quad Cab 2WD	4.7L V-8	7,350 (a5,h)
Ram 1500 Quad Cab 2WD	5.7L V-8	5,800 (a5,c)
Ram 1500 Quad Cab 2WD	5.7L V-8	7,800 (a5,f)
Ram 1500 Quad Cab 2WD	5.7L V-8	8,800 (a5,h)
Ram 1500 Quad Cab 4WD	4.7L V-8	6,100 (a5,f)
Ram 1500 Quad Cab 4WD	4.7L V-8	7,100 (a5,h)
Ram 1500 Quad Cab 4WD	5.7L V-8	7,550 (a5,f)
Ram 1500 Quad Cab 4WD	5.7L V-8	8,550 (a5,h)

Ram 1500 Crew Cab

Ram 1500 CC 2WD	4.7L V-8	6,250 (a5,f**)
Ram 1500 CC 2WD	4.7L V-8	7,250 (a5,h**)
Ram 1500 CC 2WD	5.7L V-8	5,700 (a5,c**)
Ram 1500 CC 2WD	5.7L V-8	7,700 (a5,f**)
Ram 1500 CC 2WD	5.7L V-8	8,700 (a5,h**)
Ram 1500 CC 4WD	4.7L V-8	6,000 (a5,f**)
Ram 1500 CC 4WD	4.7L V-8	7,000 (a5,h**)
Ram 1500 CC 4WD	5.7L V-8	7,450 (a5,f**)
Ram 1500 CC 4WD	5.7L V-8	8,450 (a5,h**)

**Models with Rambox are rated 100 lb less.

Manufacturer's Note: Ratings shown are for base ST models with 17-inch wheels. SLT and Laramie models, and/or models with 20-inch wheels have lower ratings, depending on model and equipment. See dealer for details.

Ram 2500 Regular Cab Longbed

Ram 2500 LB 2WD	5.7L V-8	9,550 (a5,g)
Ram 2500 LB 2WD	5.7L V-8	11,550 (a5,i)
Ram 2500 LB 2WD	6.7L I-6 TD	12,450 (m6,e)
Ram 2500 LB 2WD	6.7L I-6 TD	13,450 (m6,g)
Ram 2500 LB 2WD	6.7L I-6 TD	10,550 (a6,e)

Ram 2500 LB 2WD	6.7L I-6 TD	13,550 (a6,g)
Ram 2500 LB 2WD	6.7L I-6 TD	13,550 (a6,i)
Ram 2500 LB 4WD	5.7L V-8	9,050 (a5,g)
Ram 2500 LB 4WD	5.7L V-8	11,050 (a5,i)
Ram 2500 LB 4WD	6.7L I-6 TD	12,100 (m6,e)
Ram 2500 LB 4WD	6.7L I-6 TD	13,100 (m6,g)
Ram 2500 LB 4WD	6.7L I-6 TD	10,200 (a6,e)
Ram 2500 LB 4WD	6.7L I-6 TD	13,200 (a6,g)
Ram 2500 LB 4WD	6.7L I-6 TD	13,200 (a6,i)

Ram 2500 Quad Cab Shortbed

Ram 2500 Quad Cab SB 2WD	5.7L V-8	9,250 (a5,g)
Ram 2500 Quad Cab SB 2WD	5.7L V-8	11,250 (a5,i)
Ram 2500 Quad Cab SB 2WD	6.7L I-6 TD	12,300 (m6,e)
Ram 2500 Quad Cab SB 2WD	6.7L I-6 TD	13,300 (m6,g)
Ram 2500 Quad Cab SB 2WD	6.7L I-6 TD	10,400 (a6,e)
Ram 2500 Quad Cab SB 2WD	6.7L I-6 TD	13,400 (a6,g)
Ram 2500 Quad Cab SB 2WD	6.7L I-6 TD	13,400 (a6,i)
Ram 2500 Quad Cab SB 4WD	5.7L V-8	8,800 (a5,g)
Ram 2500 Quad Cab SB 4WD	5.7L V-8	10,800 (a5,i)
Ram 2500 Quad Cab SB 4WD	5.7L V-8	10,500 (a5,i*)
Ram 2500 Quad Cab SB 4WD	6.7L I-6 TD	11,850 (m6,e)
Ram 2500 Quad Cab SB 4WD	6.7L I-6 TD	12,850 (m6,g)
Ram 2500 Quad Cab SB 4WD	6.7L I-6 TD	9,950 (a6,e)
Ram 2500 Quad Cab SB 4WD	6.7L I-6 TD	12,950 (a6,g)
Ram 2500 Quad Cab SB 4WD	6.7L I-6 TD	12,950 (a6,i)

*Power Wagon model

Ram 2500 Quad Cab Longbed

Ram 2500 Quad Cab LB 2WD	5.7L V-8	9,100 (a5,g)
Ram 2500 Quad Cab LB 2WD	5.7L V-8	11,100 (a5,i)
Ram 2500 Quad Cab LB 2WD	6.7L I-6 TD	12,200 (m6,e)
Ram 2500 Quad Cab LB 2WD	6.7L I-6 TD	13,200 (m6,g)
Ram 2500 Quad Cab LB 2WD	6.7L I-6 TD	10,250 (a6,e)
Ram 2500 Quad Cab LB 2WD	6.7L I-6 TD	13,250 (a6,g)
Ram 2500 Quad Cab LB 2WD	6.7L I-6 TD	13,250 (a6,i)
Ram 2500 Quad Cab LB 4WD	5.7L V-8	8,650 (a5,g)
Ram 2500 Quad Cab LB 4WD	5.7L V-8	10,650 (a5,i)
Ram 2500 Quad Cab LB 4WD	6.7L I-6 TD	11,700 (m6,e)
Ram 2500 Quad Cab LB 4WD	6.7L I-6 TD	12,700 (m6,g)
Ram 2500 Quad Cab LB 4WD	6.7L I-6 TD	9,800 (a6,e)
Ram 2500 Quad Cab LB 4WD	6.7L I-6 TD	12,800 (a6,g)
Ram 2500 Quad Cab LB 4WD	6.7L I-6 TD	12,800 (a6,i)

Ram 2500 Mega Cab

Ram 2500 Mega Cab 2WD	5.7L V-8	8,850 (a5,g)
Ram 2500 Mega Cab 2WD	5.7L V-8	10,850 (a5,i)
Ram 2500 Mega Cab 2WD	6.7L I-6 TD	11,850 (m6,e)
Ram 2500 Mega Cab 2WD	6.7L I-6 TD	12,850 (m6,g)
Ram 2500 Mega Cab 2WD	6.7L I-6 TD	9,950 (a6,e)
Ram 2500 Mega Cab 2WD	6.7L I-6 TD	12,950 (a6,g)
Ram 2500 Mega Cab 2WD	6.7L I-6 TD	12,950 (a6,i)
Ram 2500 Mega Cab 4WD	5.7L V-8	8,500 (a5,i)
Ram 2500 Mega Cab 4WD	5.7L V-8	10,500 (a5,g)
Ram 2500 Mega Cab 4WD	6.7L I-6 TD	11,550 (m6,e)

Ram 2500 Mega Cab 4WD	6.7L I-6 TD	12,550 (m6,g)
Ram 2500 Mega Cab 4WD	6.7L I-6 TD	9,600 (a6,e)
Ram 2500 Mega Cab 4WD	6.7L I-6 TD	12,600 (a6,g)
Ram 2500 Mega Cab 4WD	6.7L I-6 TD	12,600 (a6,i)

Ram 3500 Regular Cab Longbed

Ram 3500 Regular Cab LB DRW 2WD	6.7L I-6 TD	12,100 (m6,e)
Ram 3500 Regular Cab LB DRW 2WD	6.7L I-6 TD	14,100 (m6,g)
Ram 3500 Regular Cab LB DRW 2WD	6.7L I-6 TD	10,150 (a6,e)
Ram 3500 Regular Cab LB DRW 2WD	6.7L I-6 TD	14,150 (a6,g)
Ram 3500 Regular Cab LB DRW 2WD	6.7L I-6 TD	16,150 (a6,i)
Ram 3500 Regular Cab LB DRW 4WD	6.7L I-6 TD	11,700 (m6,e)
Ram 3500 Regular Cab LB DRW 4WD	6.7L I-6 TD	13,700 (m6,g)
Ram 3500 Regular Cab LB DRW 4WD	6.7L I-6 TD	9,800 (a6,e)
Ram 3500 Regular Cab LB DRW 4WD	6.7L I-6 TD	13,800 (a6,g)
Ram 3500 Regular Cab LB DRW 4WD	6.7L I-6 TD	16,800 (a6,i)

Ram 3500 Quad Cab Shortbed

Ram 3500 Quad Cab SB SRW 2WD	6.7L I-6 TD	12,300 (m6,e)
Ram 3500 Quad Cab SB SRW 2WD	6.7L I-6 TD	14,300 (m6,g)
Ram 3500 Quad Cab SB SRW 2WD	6.7L I-6 TD	10,350 (a6,e)
Ram 3500 Quad Cab SB SRW 2WD	6.7L I-6 TD	14,350 (a6,g)
Ram 3500 Quad Cab SB SRW 2WD	6.7L I-6 TD	16,350 (a6,i)
Ram 3500 Quad Cab SB SRW 4WD	6.7L I-6 TD	11,900 (m6,e)
Ram 3500 Quad Cab SB SRW 4WD	6.7L I-6 TD	13,900 (m6,g)
Ram 3500 Quad Cab SB SRW 4WD	6.7L I-6 TD	10,000 (a6,e)
Ram 3500 Quad Cab SB SRW 4WD	6.7L I-6 TD	14,000 (a6,g)
Ram 3500 Quad Cab SB SRW 4WD	6.7L I-6 TD	17,000 (a6,i)

Ram 3500 Quad Cab Longbed

Ram 3500 Quad Cab LB SRW 2WD	6.7L I-6 TD	12,150 (m6,e)
Ram 3500 Quad Cab LB SRW 2WD	6.7L I-6 TD	14,150 (m6,g)
Ram 3500 Quad Cab LB SRW 2WD	6.7L I-6 TD	10,200 (a6,e)
Ram 3500 Quad Cab LB SRW 2WD	6.7L I-6 TD	14,200 (a6,g)
Ram 3500 Quad Cab LB SRW 2WD	6.7L I-6 TD	16,200 (a6,i)
Ram 3500 Quad Cab LB DRW 2WD	6.7L I-6 TD	11,750 (m6,e)
Ram 3500 Quad Cab LB DRW 2WD	6.7L I-6 TD	13,750 (m6,g)
Ram 3500 Quad Cab LB DRW 2WD	6.7L I-6 TD	9,850 (a6,e)
Ram 3500 Quad Cab LB DRW 2WD	6.7L I-6 TD	13,850 (a6,g)
Ram 3500 Quad Cab LB DRW 2WD	6.7L I-6 TD	15,850 (a6,i)
Ram 3500 Quad Cab LB SRW 4WD	6.7L I-6 TD	11,750 (m6,e)
Ram 3500 Quad Cab LB SRW 4WD	6.7L I-6 TD	13,750 (m6,g)
Ram 3500 Quad Cab LB SRW 4WD	6.7L I-6 TD	9,850 (a6,e)
Ram 3500 Quad Cab LB SRW 4WD	6.7L I-6 TD	13,850 (a6,g)
Ram 3500 Quad Cab LB SRW 4WD	6.7L I-6 TD	16,850 (a6,i)
Ram 3500 Quad Cab LB DRW 4WD	6.7L I-6 TD	11,400 (m6,e)
Ram 3500 Quad Cab LB DRW 4WD	6.7L I-6 TD	13,400 (m6,g)
Ram 3500 Quad Cab LB DRW 4WD	6.7L I-6 TD	9,450 (a6,e)
Ram 3500 Quad Cab LB DRW 4WD	6.7L I-6 TD	13,450 (a6,g)
Ram 3500 Quad Cab LB DRW 4WD	6.7L I-6 TD	16,450 (a6,i)

Ram 3500 Mega Cab

Ram 3500 Mega Cab SRW 2WD	6.7L I-6 TD	12,000 (m6,e)
Ram 3500 Mega Cab SRW 2WD	6.7L I-6 TD	14,000 (m6,g)
Ram 3500 Mega Cab SRW 2WD	6.7L I-6 TD	10,050 (a6,e)

Ram 3500 Mega Cab SRW 2WD	6.7L I-6 TD	14,050 (a6,g)
Ram 3500 Mega Cab SRW 2WD	6.7L I-6 TD	16,050 (a6,i)
Ram 3500 Mega Cab DRW 2WD	6.7L I-6 TD	11,600 (m6,e)
Ram 3500 Mega Cab DRW 2WD	6.7L I-6 TD	13,600 (m6,g)
Ram 3500 Mega Cab DRW 2WD	6.7L I-6 TD	9,650 (a6,e)
Ram 3500 Mega Cab DRW 2WD	6.7L I-6 TD	13,650 (a6,g)
Ram 3500 Mega Cab DRW 2WD	6.7L I-6 TD	15,650 (a6,i)
Ram 3500 Mega Cab SRW 4WD	6.7L I-6 TD	11,650 (m6,e)
Ram 3500 Mega Cab SRW 4WD	6.7L I-6 TD	13,650 (m6,g)
Ram 3500 Mega Cab SRW 4WD	6.7L I-6 TD	9,700 (a6,e)
Ram 3500 Mega Cab SRW 4WD	6.7L I-6 TD	13,700 (a6,g)
Ram 3500 Mega Cab SRW 4WD	6.7L I-6 TD	16,700 (a6,i)
Ram 3500 Mega Cab DRW 4WD	6.7L I-6 TD	11,250 (m6,e)
Ram 3500 Mega Cab DRW 4WD	6.7L I-6 TD	13,250 (m6,g)
Ram 3500 Mega Cab DRW 4WD	6.7L I-6 TD	9,300 (a6,e)
Ram 3500 Mega Cab DRW 4WD	6.7L I-6 TD	13,300 (a6,g)
Ram 3500 Mega Cab DRW 4WD	6.7L I-6 TD	16,300 (a6,i)

Ram 3500/4500/5500 Chassis Cab

3500 Regular Cab SRW 2WD	6.7L I-6 TD	12,500 (m,e)
3500 Regular Cab SRW 2WD	6.7L I-6 TD	17,500 (m,g/i)
3500 Regular Cab SRW 2WD	6.7L I-6 TD	16,450 (a6,g)
3500 Regular Cab SRW 2WD	6.7L I-6 TD	17,45 (a6,i)
3500 Regular Cab SRW 4WD	6.7L I-6 TD	12,250 (m,e)
3500 Regular Cab SRW 4WD	6.7L I-6 TD	17,250 (m,g/i)
3500 Regular Cab SRW 4WD	6.7L I-6 TD	16,200 (a6,g)
3500 Regular Cab SRW 4WD	6.7L I-6 TD	17,200 (a6,i)
3500 Regular Cab DRW 2WD	5.7L V-8	11,050 (a5,i)
3500 Regular Cab DRW 2WD	6.7L I-6 TD	12,200 (m,e)
3500 Regular Cab DRW 2WD	6.7L I-6 TD	17,200 (m,g/i)
3500 Regular Cab DRW 2WD	6.7L I-6 TD	17,150 (a6,i)
3500 Regular Cab DRW 4WD	5.7L V-8	10,800 (a5,i)
3500 Regular Cab DRW 4WD	6.7L I-6 TD	11,950 (m,e)
3500 Regular Cab DRW 4WD	6.7L I-6 TD	16,950 (m,g/i)
3500 Regular Cab DRW 4WD	6.7L I-6 TD	16,900 (a6,i)
3500 Quad Cab SRW 2WD	6.7L I-6 TD	12,100 (m,e)
3500 Quad Cab SRW 2WD	6.7L I-6 TD	17,100 (m,g/i)
3500 Quad Cab SRW 2WD	6.7L I-6 TD	16,050 (a6,g)
3500 Quad Cab SRW 2WD	6.7L I-6 TD	17,050 (a6,i)
3500 Quad Cab SRW 4WD	6.7L I-6 TD	11,900 (m,e)
3500 Quad Cab SRW 4WD	6.7L I-6 TD	16,900 (m,g/i)
3500 Quad Cab SRW 4WD	6.7L I-6 TD	15,850 (a6,g)
3500 Quad Cab SRW 4WD	6.7L I-6 TD	16,850 (a6,i)
3500 Quad Cab DRW 2WD	5.7L V-8	10,700 (a5,i)
3500 Quad Cab DRW 2WD	6.7L I-6 TD	11,850 (m,e)
3500 Quad Cab DRW 2WD	6.7L I-6 TD	16,850 (m,g/i)
3500 Quad Cab DRW 2WD	6.7L I-6 TD	16,750 (a6,i)
3500 Quad Cab DRW 4WD	5.7L V-8	10,450 (a5,i)
3500 Quad Cab DRW 4WD	6.7L I-6 TD	11,600 (m,e)
3500 Quad Cab DRW 4WD	6.7L I-6 TD	16,600 (m,g/i)
3500 Quad Cab DRW 4WD	6.7L I-6 TD	16,550 (a6,i)
4500 Regular Cab DRW 2WD	6.7L I-6 TD	18,400 (m)
4500 Regular Cab DRW 2WD	6.7L I-6 TD	18,350 (a6)
4500 Regular Cab DRW 4WD	6.7L I-6 TD	18,050 (m)
4500 Regular Cab DRW 4WD	6.7L I-6 TD	18,000 (a6)

4500 Quad Cab DRW 2WD	6.7L I-6 TD	18,000 (m)
4500 Quad Cab DRW 2WD	6.7L I-6 TD	17,900 (a)
4500 Quad Cab DRW 4WD	6.7L I-6 TD	17,700 (m)
4500 Quad Cab DRW 4WD	6.7L I-6 TD	17,600 (a)
5500 Regular Cab DRW 2WD	6.7L I-6 TD	18,350 (m)
5500 Regular Cab DRW 2WD	6.7L I-6 TD	18,300 (a6)
5500 Regular Cab DRW 4WD	6.7L I-6 TD	18,000 (m)
5500 Regular Cab DRW 4WD	6.7L I-6 TD	17,950
5500 Quad Cab DRW 2WD	6.7L I-6 TD	17,950 (m)
5500 Quad Cab DRW 2WD	6.7L I-6 TD	17,900 (a6)
5500 Quad Cab DRW 4WD	6.7L I-6 TD	17,600 (m)
5500 Quad Cab DRW 4WD	6.7L I-6 TD	17,550

Sprinter

Sprinter	All	5,000
----------	-----	-------

Manufacturer's Note: Weights shown are for 60-inch cab-to-axle models in ST trim. Longer cab-to-axle lengths will reduce tow rating by as much as 300 lb, depending on model. See dealer for details.

Key to Dodge Section

- a = Automatic Transmission
- a4 = Automatic Transmission, four speed
- a5 = Automatic Transmission, five speed
- a6 = Automatic Transmission, six speed
- m = Manual Transmission
- c = 3:21:1 axle ratio
- e = 3.42:1 axle ratio
- f = 3.55:1 axle ratio
- g = 3.73:1 axle ratio
- h = 3.92:1 axle ratio
- i = 4.10:1 axle ratio
- CC = Crew Cab
- QC = Quad Cab
- LB = Longbed
- SB = Shortbed
- SRW = Single Rear Wheels
- DRW = Dual Rear Wheels (dually)
- TD = Turbodiesel
- t = Tow Package Required

FORD

E-Series Van/Wagon

E-150 Van	4.6L V-8	6,000 (e)
E-150 Van	4.6L V-8	6,500 (f)
E-150 Van	5.4L V-8	7,400 (e)
E-250 Van	4.6L V-8	6,000 (e)
E-250 Van	4.6L V-8	6,400 (f)
E-250 Van	5.4L V-8	7,400 (f)
E-250 Extended Van	4.6L V-8	5,900 (e)
E-250 Extended Van	4.6L V-8	6,300 (f)
E-250 Extended Van	5.4L V-8	7,300 (e)
E-350 Super Duty Van	5.4L V-8	7,300 (e)
E-350 Super Duty Van	5.4L V-8	7,300 (f)
E-350 Super Duty Van	6.8L V-10	9,100 (e)
E-350 Super Duty Van	6.8L V-10	10,000 (f)
E-350 Super Duty Van	6.0L V-8 TD	9,500 (d)
E-350 Super Duty Van	6.0L V-8 TD	10,000 (f)
E-350 Super Duty Extended Van	5.4L V-8	7,200 (e)
E-350 Super Duty Extended Van	5.4L V-8	7,200 (f)
E-350 Super Duty Extended Van	6.8L V-10	9,000 (e)
E-350 Super Duty Extended Van	6.8L V-10	10,000 (f)

E-350 Super Duty Extended Van	6.0L V-8 TD	9,400 (d)
E-350 Super Duty Extended Van	6.0L V-8 TD	10,000 (f)
E-150 Wagon	4.6L V-8	6,000 (f)
E-150 Wagon	5.4L V-8	7,000 (e)
E-350 Super Duty Wagon	5.4L V-8	6,700 (e)
E-350 Super Duty Wagon	6.8L V-10	8,500 (e)
E-350 Super Duty Wagon	6.0L V-8 TD	8,900 (e)
E-350 Super Duty Wagon	6.0L V-8 TD	10,000 (f)
E-350 Super Duty Ext. Wagon	5.4L V-8	6,500 (e)
E-350 Super Duty Ext. Wagon	6.8L V-10	10,000 (f)

Edge, Escape, Explorer, Expedition, Flex

Edge	3.5L V-6	2,000
Edge	3.5L V-6	3,500 (t)
Escape 2WD/4WD	3.0L V-6	3,500 (t)
Explorer	4.0L V-6	3,500 (d,all)
Explorer 2WD	4.0L V-6	5,375 (e)
Explorer 4WD/AWD	4.0L V-6	5,205 (e)
Explorer	4.6L V-8	3,500d (all)
Explorer 2WD	4.6L V-8	7,285 (d,t)
Explorer 4WD/AWD	4.6L V-8	7,115 (d,t)
Sport Trac 2WD	4.0L V-6	5,250 (e)
Sport Trac 2WD/AWD	4.0L V-6	5,080 (e)
Sport Trac 2WD	4.6L V-8	7,160 (d)
Sport Trac 2WD/AWD	4.6L V-8	6,990 (d)
Expedition 2WD/4WD	5.4L V-8	6,000 (all)
Expedition 2WD	5.4L V-8	9,200 (t)
Expedition 4WD	5.4L V-8	9,000 (t)
Expedition EL 2WD/4WD	5.4L V-8	6,000 (all)
Expedition EL 2WD	5.4L V-8	8,900 (t)
Expedition EL 4WD	5.4L V-8	8,700 (t)
Flex	3.5L V-6	2,000
Flex	3.5L V-6	4,500 (t)

Ranger

Ranger Regular Cab SB 2WD	2.3L I-4	2,240
Ranger Regular Cab LB 2WD	2.3L I-4	2,220
Ranger Regular Cab LB 2WD	4.0L V-6	6,000
Ranger SuperCab 2WD	2.3L I-4	2,080 (a,f)
Ranger SuperCab 2WD	4.0L V-6	3,400 (m)
Ranger SuperCab 2WD	4.0L V-6	3,220 (m*)
Ranger SuperCab 2WD	4.0L V-6	5,860 (a,d)
Ranger SuperCab 2WD	4.0L V-6	5680 (a,d*)
Ranger SuperCab 4WD	4.0L V-6	3,140 (m)
Ranger SuperCab 4WD	4.0L V-6	5,600 (a,e)
Ranger SuperCab 4WD	4.0L V-6	5,600 (a,f)

* = Sport model.

F-150

F-150 Reg. Cab Std. Bed 2WD	4.6L V-8 2V	5,400 (a4,d)
F-150 Reg. Cab LB 2WD	4.6L V-8 2V	5,900 (a4,e)
F-150 Reg. Cab LB 2WD	4.6L V-8 2V	5,500 (a4,d)
F-150 Reg. Cab LB 2WD	4.6L V-8 2V	6,000 (a4,e)
F-150 Reg. Cab LB 2WD	4.6L V-8 3V	8000 (a6,c)
F-150 Reg. Cab LB 2WD	4.6L V-8 3V	8,400 (a6,d)

F-150 Reg. Cab LB 2WD	5.4L V-8	8,000 (a6,b)
F-150 Reg. Cab LB 2WD	5.4L V-8	9,800 (a6,d)
F-150 Reg. Cab LB 2WD	5.4L V-8	11,300 (a6,e,t)
F-150 Reg. Cab Std. Bed 4WD	4.6L V-8 2V	5,700 (a4,e)
F-150 Reg. Cab Std. Bed 4WD	4.6L V-8 3V	7,700 (a6,d)
F-150 Reg. Cab Std. Bed 4WD	4.6L V-8 3V	8,000 (a6,e)
F-150 Reg. Cab Std. Bed 4WD	5.4L V-8	7,700 (a6,c)
F-150 Reg. Cab Std. Bed 4WD	5.4L V-8	8,600 (a6,d/e)
F-150 Reg. Cab LB 4WD	4.6L V-8 2V	5,800 (a4,e)
F-150 Reg. Cab LB 4WD	4.6L V-8 3V	7,800 (a6,d)
F-150 Reg. Cab LB 4WD	4.6L V-8 3V	8,200 (a6,e)
F-150 Reg. Cab LB 4WD	5.4L V-8	7,800 (a6,c)
F-150 Reg. Cab LB 4WD	5.4L V-8	9,500 (a6,d/e)
F-150 Reg. Cab LB 4WD	5.4L V-8	11,300 (a6,e,t)
F-150 SuperCab Shortbed 2WD	4.6L V-8 2V	5,200 (a4,d)
F-150 SuperCab Shortbed 2WD	4.6L V-8 2V	5,700 (a4,e)
F-150 SuperCab Shortbed 2WD	4.6L V-8 3V	7,800 (a6,c)
F-150 SuperCab Shortbed 2WD	4.6L V-8 3V	8,200 (a6,d)
F-150 SuperCab Shortbed 2WD	5.4L V-8	7,800 (a6,b)
F-150 SuperCab Shortbed 2WD	5.4L V-8	8,600 (a6,d)
F-150 SuperCab Std. Bed 2WD	4.6L V-8 2V	5,300 (a4,d)
F-150 SuperCab Std. Bed 2WD	4.6L V-8 2V	5,800 (a4,e)
F-150 SuperCab Std. Bed 2WD	4.6L V-8 3V	8,200 (a6,c)
F-150 SuperCab Std. Bed 2WD	4.6L V-8 3V	9,500 (a6,d)
F-150 SuperCab Std. Bed 2WD	5.4L V-8	8,600 (a6,b)
F-150 SuperCab Std. Bed 2WD	5.4L V-8	9,800 (a6,d)
F-150 SuperCab Std. Bed 2WD	5.4L V-8	11,300 (a6,e,t)
F-150 SuperCab LB 2WD	5.4L V-8	11,300 (a6,e)
F-150 SuperCab Shortbed 4WD	4.6L V-8 2V	5,400 (a4,e)
F-150 SuperCab Shortbed 4WD	4.6L V-8 3V	7,500 (a6,d)
F-150 SuperCab Shortbed 4WD	4.6L V-8 3V	8,000 (a6,e)
F-150 SuperCab Shortbed 4WD	5.4L V-8	7,600 (a6,c)
F-150 SuperCab Shortbed 4WD	5.4L V-8	8,400 (a6,d/e)
F-150 SuperCab Std. Bed 4WD	4.6L V-8 2V	5,500 (a4,e)
F-150 SuperCab Std. Bed 4WD	4.6L V-8 3V	7,900 (a6,d)
F-150 SuperCab Std. Bed 4WD	4.6L V-8 3V	9,400 (a6,e)
F-150 SuperCab Std. Bed 4WD	5.4L V-8	8,300 (a6,c)
F-150 SuperCab Std. Bed 4WD	5.4L V-8	9,700 (a6,d/e)
F-150 SuperCab Std. Bed 4WD	5.4L V-8	11,200 (a6,d/e,t)
F-150 SuperCab LB 4WD	5.4L V-8	11,000 (a6,e)
F-150 SuperCrew Cab Shortbed 2WD	4.6L V-8 2V	5,200 (a4,d)
F-150 SuperCrew Cab Shortbed 2WD	4.6L V-8 2V	5,700 (a4,e)
F-150 SuperCrew Cab Shortbed 2WD	4.6L V-8 3V	7,500 (a6,b)
F-150 SuperCrew Cab Shortbed 2WD	4.6L V-8 3V	8,100 (a6,c)
F-150 SuperCrew Cab Shortbed 2WD	4.6L V-8 3V	9,500 (a6,d)
F-150 SuperCrew Cab Shortbed 2WD	5.4L V-8	8,500 (a6,b)
F-150 SuperCrew Cab Shortbed 2WD	5.4L V-8	9,800 (a6,d)
F-150 SuperCrew Cab Shortbed 2WD	5.4L V-8	11,300 (a6,e)
F-150 SuperCrew Cab Shortbed 4WD	4.6L V-8 3V	7,800 (a6,d)
F-150 SuperCrew Cab Shortbed 4WD	4.6L V-8 3V	9,300 (a6,e)
F-150 SuperCrew Cab Shortbed 4WD	5.4L V-8	8,200 (a6,c)
F-150 SuperCrew Cab Shortbed 4WD	5.4L V-8	9,700 (a6,d/e)
F-150 SuperCrew Cab Shortbed 4WD	5.4L V-8	11,200 (a6,d/e,t)
F-150 SuperCrew Cab Std. Bed 2WD	4.6L V-8 2V	5,100 (a4,d)
F-150 SuperCrew Cab Std. Bed 2WD	4.6L V-8 2V	5,600 (a4,e)

F-150 SuperCrew Cab Std. Bed 2WD	4.6L V-8 3V	8,000 (a6,c)
F-150 SuperCrew Cab Std. Bed 2WD	4.6L V-8 3V	9,300 (a6,d)
F-150 SuperCrew Cab Std. Bed 2WD	5.4L V-8	8,400 (b)
F-150 SuperCrew Cab Std. Bed 2WD	5.4L V-8	9,700 (d)
F-150 SuperCrew Cab Std. Bed 2WD	5.4L V-8	11,300 (e)
F-150 SuperCrew Cab Std. Bed 4WD	4.6L V-8 3V	7,600 (a6,d)
F-150 SuperCrew Cab Std. Bed 4WD	4.6L V-8 3V	9,200 (a6,e)
F-150 SuperCrew Cab Std. Bed 4WD	5.4L V-8	8,100 (a6,c)
F-150 SuperCrew Cab Std. Bed 4WD	5.4L V-8	9,600 (a6,d/e)
F-150 SuperCrew Cab Std. Bed 4WD	5.4L V-8	11,100 (a6,d/e,t)

F-250/F-350/F-450 Super Duty, Conventional Towing, Automatic Transmission

F-250/350 Reg. Cab SRW 2WD	5.4L V-8	10,200 (e)
F-250/350 Reg. Cab SRW 2WD	5.4L V-8	12,200 (f)
F-250/350 Reg. Cab SRW 2WD	6.8L V-10	12,500 (f/g)
F-250/350 Reg. Cab SRW 2WD	6.4L V-8 TD	12,500 (all)
F-250/350 Reg. Cab SRW 4WD	5.4L V-8	9,800 (e)
F-250/350 Reg. Cab SRW 4WD	5.4L V-8	11,800 (f)
F-250/350 Reg. Cab SRW 4WD	6.8L V-10	12,500 (f/g)
F-250/350 Reg. Cab SRW 4WD	6.4L V-8 TD	12,500 (all)
F-350 Reg. Cab DRW 2WD	5.4L V-8	12,200 (f)
F-350 Reg. Cab DRW 2WD	6.8L V-10	15,000 (all)
F-350 Reg. Cab DRW 2WD	6.4L V-8 TD	15,000 (all)
F-350 Reg. Cab DRW 4WD	5.4L V-8	11,800 (f)
F-350 Reg. Cab DRW 4WD	6.8L V-10	14,600 (f)
F-350 Reg. Cab DRW 4WD	6.8L V-10	15,000 (g)
F-250/F350 SC SRW 2WD	5.4L V-8	10,000 (e)
F-250/F350 SC SRW 2WD	5.4L V-8	12,000 (f)
F-250/F350 SC SRW 2WD	6.8L V-10	12,500 (all)
F-250/F350 SC SRW 2WD	6.4L V-8 TD	12,500 (all)
F-250/F350 SC SRW 4WD	5.4L V-8	9,500 (e)
F-250/F350 SC SRW 4WD	5.4L V-8	11,500 (f)
F-250/F350 SC SRW 4WD	6.8L V-10	12,500 (all)
F-250/F350 SC SRW 4WD	6.4L V-8 TD	12,500 (all)
F-350 SC DRW 2WD	5.4L V-8	11,800 (f)
F-350 SC DRW 2WD	6.8 V-10	14,700 (f)
F-350 SC DRW 2WD	6.8 V-10	15,000 (g)
F-350 SC DRW 2WD	6.4L V-8 TD	15,000 (all)
F-350 SC DRW 4WD	5.4L V-8	11,400 (f)
F-350 SC DRW 4WD	6.8 V-10	14,300 (f)
F-350 SC DRW 4WD	6.8 V-10	15,000 (g)
F-350 SC DRW 4WD	6.4L V-8 TD	15,000 (all)
F-250/350 CC SRW 2WD	5.4L V-8	9,700 (e)
F-250/350 CC SRW 2WD	5.4L V-8	11,700 (f)
F-250/350 CC SRW 2WD	6.8L V-10	12,500 (all)
F-250/350 CC SRW 2WD	6.4L V-8 TD	12,500 (all)
F-250/350 CC SRW 4WD	5.4L V-8	9,300 (e)
F-250/350 CC SRW 4WD	5.4L V-8	11,300 (f)
F-250/350 CC SRW 4WD	6.8L V-10	12,500 (all)
F-250/350 CC SRW 4WD	6.4L V-8 TD	12,500 (all)
F-350 CC DRW 2WD	6.8L V-10	14,500 (f)
F-350 CC DRW 2WD	6.8L V-10	15,000 (g)
F-350 CC DRW 2WD	6.4L V-8 TD	15,000 (all)
F-350 CC DRW 4WD	6.8L V-10	14,000 (f)

F-350 CC DRW 4WD	6.8L V-10	15,000 (g)
F-350 CC DRW 4WD	6.4L V-8 TD	15,000 (all)
F-450 DRW 2WD	6.4L V-8 TD	16,000 (g)
F-450 DRW 4WD	6.4L V-8 TD	16,000 (g)

F-250/F-350/F-450 Super Duty, Fifth-Wheel Towing, Automatic Transmission

F-250/F-350 Regular Cab SRW 2WD	5.4L V-8	10,200 (e)
F-250/F-350 Regular Cab SRW 2WD	5.4L V-8	12,200 (f)
F-250/F-350 Regular Cab SRW 2WD	6.8L V-10	15,000 (f)
F-250/F-350 Regular Cab SRW 2WD	6.8L V-10	16,800 (g)
F-250/F-350 Regular Cab SRW 2WD	6.4L V-8 TD	16,300 (d/e)
F-250/F-350 Regular Cab SRW 4WD	5.4L V-8	9,800 (e)
F-250/F-350 Regular Cab SRW 4WD	5.4L V-8	11,800 (f)
F-250/F-350 Regular Cab SRW 4WD	6.8L V-10	14,600 (f)
F-250/F-350 Regular Cab SRW 4WD	6.8L V-10	16,500 (g)
F-250/F-350 Regular Cab SRW 4WD	6.4L V-8 TD	15,800 (e)
F-350 Regular Cab DRW 2WD	5.4L V-8	12,200 (f)
F-350 Regular Cab DRW 2WD	6.8L V-10	15,100 (f)
F-350 Regular Cab DRW 2WD	6.8L V-10	16,600 (g)
F-350 Regular Cab DRW 2WD	6.4 V-8 TD	15,800 (d)
F-350 Regular Cab DRW 2WD	6.4 V-8 TD	16,300 (e/f)
F-350 Regular Cab DRW 2WD	6.4 V-8 TD	18,800 (g,t)
F-350 Regular Cab DRW 4WD	5.4L V-8	11,800 (f)
F-350 Regular Cab DRW 4WD	6.8L V-10	14,600 (f)
F-350 Regular Cab DRW 4WD	6.8L V-10	16,100 (g)
F-350 Regular Cab DRW 4WD	6.4 V-8 TD	15,800 (e/f)
F-350 Regular Cab DRW 4WD	6.4 V-8 TD	18,300 (g,t)
F-250/F350 SuperCab SRW 2WD	5.4L V-8	10,000 (e)
F-250/F350 SuperCab SRW 2WD	5.4L V-8	12,000 (f)
F-250/F350 SuperCab SRW 2WD	6.8L V-10	14,800 (f)
F-250/F350 SuperCab SRW 2WD	6.8L V-10	16,600 (g)
F-250/F350 SuperCab SRW 2WD	6.4L V-8 TD	16,000 (d/e)
F-250/F350 SuperCab SRW 4WD	5.4L V-8	9,500 (e)
F-250/F350 SuperCab SRW 4WD	5.4L V-8	11,500 (f)
F-250/F350 SuperCab SRW 4WD	6.8L V-10	14,400 (f)
F-250/F350 SuperCab SRW 4WD	6.8L V-10	16,300 (g)
F-250/F350 SuperCab SRW 4WD	6.8L V-10	15,600 (e)
F-350 SuperCab DRW 2WD	5.4L V-8	11,800 (f)
F-350 SuperCab DRW 2WD	6.8L V-10	14,700 (f)
F-350 SuperCab DRW 2WD	6.8L V-10	16,200 (g)
F-350 SuperCab DRW 2WD	6.4L V-8 TD	15,600 (d)
F-350 SuperCab DRW 2WD	6.4L V-8 TD	15,900 (e/f)
F-350 SuperCab DRW 2WD	6.4L V-8 TD	18,400 (g,t)
F-350 SuperCab DRW 4WD	5.4L V-8	11,400 (f)
F-350 SuperCab DRW 4WD	6.8L V-10	14,300 (f)
F-350 SuperCab DRW 4WD	6.8L V-10	15,800 (g)
F-350 SuperCab DRW 4WD	6.4L V-8 TD	15,500 (e/f)
F-350 SuperCab DRW 4WD	6.4L V-8 TD	18,000 (g,t)
F-250/F-350 Crew Cab SRW 2WD	5.4L V-8	9,700 (e)
F-250/F-350 Crew Cab SRW 2WD	5.4L V-8	11,700 (f)
F-250/F-350 Crew Cab SRW 2WD	6.8L V-10	14,600 (f)
F-250/F-350 Crew Cab SRW 2WD	6.8L V-10	16,500 (g)
F-250/F-350 Crew Cab SRW 2WD	6.4L V-8 TD	15,800 (d/e)
F-250/F-350 Crew Cab SRW 4WD	5.4L V-8	9,300 (e)

F-250/F-350 Crew Cab SRW 4WD	5.4L V-8	11,300 (f)
F-250/F-350 Crew Cab SRW 4WD	6.8L V-10	14,100 (f)
F-250/F-350 Crew Cab SRW 4WD	6.8L V-10	16,100 (g)
F-250/F-350 Crew Cab SRW 4WD	6.4L V-8 TD	15,300 (e)
F-350 Crew Cab DRW 2WD	6.8L V-10	14,500 (f)
F-350 Crew Cab DRW 2WD	6.8L V-10	16,000 (g)
F-350 Crew Cab DRW 2WD	6.4L V-8 TD	15,700 (e/f)
F-350 Crew Cab DRW 2WD	6.4L V-8 TD	18,200 (g,t)
F-350 Crew Cab DRW 4WD	6.8L V-10	14,000 (f)
F-350 Crew Cab DRW 4WD	6.8L V-10	15,500 (g)
F-350 Crew Cab DRW 4WD	6.4L V-8 TD	15,200 (e/f)
F-350 Crew Cab DRW 4WD	6.4L V-8 TD	17,700 (g,t)
F-450 Crew Cab DRW 2WD	6.4L V-8 TD	24,600 (g,t)
F-450 Crew Cab DRW 4WD	6.4L V-8 TD	24,200 (g,t)

F-250/F-350/F-450 Super Duty, Fifth-Wheel Towing, Manual Transmission

F-250/F-350 Reg. Cab SRW 2WD	5.4L V-8	9,200 (e)
F-250/F-350 Reg. Cab SRW 2WD	5.4L V-8	11,200 (f)
F-250/F-350 Reg. Cab SRW 2WD	6.8L V-10	14,000 (f)
F-250/F-350 Reg. Cab SRW 2WD	6.8L V-10	16,000 (g)
F-250/F-350 Reg. Cab SRW 2WD	6.4L V-8 TD	16,300 (e)
F-250/F-350 Reg. Cab SRW 4WD	5.4L V-8	8,800 (e)
F-250/F-350 Reg. Cab SRW 4WD	5.4L V-8	10,800 (f)
F-250/F-350 Reg. Cab SRW 4WD	6.8L V-10	13,600 (f)
F-250/F-350 Reg. Cab SRW 4WD	6.8L V-10	15,600 (g)
F-250/F-350 Reg. Cab SRW 4WD	6.4L V-8 TD	15,800 (e)
F-350 Reg. Cab DRW 2WD	5.4L V-8	11,200 (f)
F-350 Reg. Cab DRW 2WD	6.8L V-10	14,100 (f)
F-350 Reg. Cab DRW 2WD	6.8L V-10	16,100 (g)
F-350 Reg. Cab DRW 2WD	6.4L V-8 TD	16,300 (e/f)
F-350 Reg. Cab DRW 4WD	5.4L V-8	10,800 (f)
F-350 Reg. Cab DRW 4WD	6.8L V-10	13,600 (f)
F-350 Reg. Cab DRW 4WD	6.8L V-10	15,600 (g)
F-350 Reg. Cab DRW 4WD	6.4L V-8 TD	15,800 (e/f)
F-250/F-350 SuperCab SRW 2WD	5.4L V-8	9,000 (e)
F-250/F-350 SuperCab SRW 2WD	5.4L V-8	11,000 (f)
F-250/F-350 SuperCab SRW 2WD	6.8L V-10	13,800 (f)
F-250/F-350 SuperCab SRW 2WD	6.8L V-10	15,700 (g)
F-250/F-350 SuperCab SRW 2WD	6.4L V-8 TD	15,900 (e)
F-250/F-350 SuperCab SRW 4WD	5.4L V-8	8,300 (e)
F-250/F-350 SuperCab SRW 4WD	5.4L V-8	10,300 (f)
F-250/F-350 SuperCab SRW 4WD	6.8L V-10	13,100 (f)
F-250/F-350 SuperCab SRW 4WD	6.8L V-10	15,100 (g)
F-250/F-350 SuperCab SRW 4WD	6.4L V-8 TD	15,300 (e)
F-350 SuperCab DRW 2WD	5.4L V-8	10,800 (f)
F-350 SuperCab DRW 2WD	6.8L V-10	13,700 (f)
F-350 SuperCab DRW 2WD	6.8L V-10	15,700 (g)
F-350 SuperCab DRW 2WD	6.4L V-8 TD	15,900 (e/f)
F-350 SuperCab DRW 4WD	5.4L V-8	10,400 (f)
F-350 SuperCab DRW 4WD	6.8L V-10	13,300 (f)
F-350 SuperCab DRW 4WD	6.8L V-10	15,300 (g)
F-350 SuperCab DRW 4WD	6.4L V-8 TD	15,500 (e/f)
F-250/F-350 Crew Cab SRW 2WD	5.4L V-8	8,700 (e)
F-250/F-350 Crew Cab SRW 2WD	5.4L V-8	10,700 (f)

F-250/F-350 Crew Cab SRW 2WD	6.8L V-10	13,700 (f)
F-250/F-350 Crew Cab SRW 2WD	6.8L V-10	15,600 (g)
F-250/F-350 Crew Cab SRW 2WD	6.4L V-8 TD	15,800 (e)
F-250/F-350 Crew Cab SRW 4WD	5.4L V-8	8,300 (e)
F-250/F-350 Crew Cab SRW 4WD	5.4L V-8	10,300 (f)
F-250/F-350 Crew Cab SRW 4WD	6.8L V-10	13,100 (f)
F-250/F-350 Crew Cab SRW 4WD	6.8L V-10	15,100 (g)
F-250/F-350 Crew Cab SRW 4WD	6.4L V-8 TD	15,300 (e)
F-350 Crew Cab DRW 2WD	6.8L V-10	13,500 (f)
F-350 Crew Cab DRW 2WD	6.8L V-10	15,500 (g)
F-350 Crew Cab DRW 2WD	6.4L V-8 TD	15,700 (e/f)
F-350 Crew Cab DRW 4WD	6.8L V-10	13,000 (f)
F-350 Crew Cab DRW 4WD	6.8L V-10	15,000 (g)
F-350 Crew Cab DRW 4WD	6.4L V-8 TD	15,200 (e/f)
F-450 Crew Cab DRW 2WD	6.4L V-8 TD	18,600 (g,t)
F-450 Crew Cab DRW 4WD	6.4L V-8 TD	18,200 (g,t)

F-350/F-450/F-550 Super Duty Chassis Cab, Conventional Towing, Automatic Transmission

F-350 Reg. Chassis Cab SRW 2WD	5.4L V-8	9,500 (e)
F-350 Reg. Chassis Cab SRW 2WD	5.4L V-8	11,500 (f)
F-350 Reg. Chassis Cab SRW 2WD	6.8 V-10	12,500 (all)
F-350 Reg. Chassis Cab SRW 2WD	6.4L V-8 TD	12,500 (all)
F-350 Reg. Chassis Cab SRW 4WD	5.4L V-8	9,100 (e)
F-350 Reg. Chassis Cab SRW 4WD	5.4L V-8	11,100 (f)
F-350 Reg. Chassis Cab SRW 4WD	6.8 V-10	12,500 (all)
F-350 Reg. Chassis Cab SRW 4WD	6.4L V-8 TD	12,500 (all)
F-350 Reg. Chassis Cab DRW 2WD	5.4L V-8	9,600 (e)
F-350 Reg. Chassis Cab DRW 2WD	5.4L V-8	11,600 (f)
F-350 Reg. Chassis Cab DRW 2WD	6.8L V-10	14,500 (f)
F-350 Reg. Chassis Cab DRW 2WD	6.8L V-10	15,000 (g)
F-350 Reg. Chassis Cab DRW 2WD	6.4L V-8 TD	15,000 (e/f)
F-350 Reg. Chassis Cab DRW 4WD	5.4L V-8	9,200 (e)
F-350 Reg. Chassis Cab DRW 4WD	5.4L V-8	11,200 (f)
F-350 Reg. Chassis Cab DRW 4WD	6.8L V-10	14,100 (f)
F-350 Reg. Chassis Cab DRW 4WD	6.8L V-10	15,000 (g)
F-350 Reg. Chassis Cab DRW 4WD	6.4L V-8 TD	15,000 (e/f)
F-450 Reg. Chassis Cab DRW 2WD	6.8L V-10	16,000 (all)
F-450 Reg. Chassis Cab DRW 2WD	6.4L V-8 TD	16,000 (all)
F-450 Reg. Chassis Cab DRW 4WD	6.8L V-10	16,000 (all)
F-450 Reg. Chassis Cab DRW 4WD	6.4L V-8 TD	16,000 (all)
F-550 Reg. Chassis Cab DRW 2WD	6.8L V-10	16,000 (all)
F-550 Reg. Chassis Cab DRW 2WD	6.4L V-8 TD	16,000 (all)
F-550 Reg. Chassis Cab DRW 4WD	6.8L V-10	16,000 (all)
F-550 Reg. Chassis Cab DRW 4WD	6.4L V-8 TD	16,000 (all)
F-350 Super Chassis Cab SRW 2WD	5.4L V-8	9,200 (e)
F-350 Super Chassis Cab SRW 2WD	5.4L V-8	11,200 (f)
F-350 Super Chassis Cab SRW 2WD	6.8L V-10	12,500 (all)
F-350 Super Chassis Cab SRW 2WD	6.4L V-8 TD	12,500 (all)
F-350 Super Chassis Cab SRW 4WD	5.4L V-8	8,700 (e)
F-350 Super Chassis Cab SRW 4WD	5.4L V-8	10,700 (f)
F-350 Super Chassis Cab SRW 4WD	6.8L V-10	12,500 (all)
F-350 Super Chassis Cab SRW 4WD	5.4L V-8	12,500 (all)
F-350 Super Chassis Cab DRW 2WD	6.8L V-10	14,100 (f)
F-350 Super Chassis Cab DRW 2WD	6.8L V-10	15,000 (g)

F-350 Super Chassis Cab DRW 2WD	6.4L V-8 TD	15,000 (all)
F-350 Super Chassis Cab DRW 4WD	6.8L V-10	13,700 (f)
F-350 Super Chassis Cab DRW 4WD	6.8L V-10	15,000 (g)
F-350 Super Chassis Cab DRW 4WD	6.4L V-8 TD	14,900 (e/f)
F-450 Super Chassis Cab DRW 2WD	6.8L V-10	16,000 (all)
F-450 Super Chassis Cab DRW 2WD	6.4L V-8 TD	16,000 (all)
F-450 Super Chassis Cab DRW 4WD	6.8L V-10	16,000 (all)
F-450 Super Chassis Cab DRW 4WD	6.4L V-8 TD	16,000 (all)
F-550 Super Chassis Cab DRW 2WD	6.8L V-10	16,000 (all)
F-550 Super Chassis Cab DRW 2WD	6.4L V-8 TD	16,000 (all)
F-550 Super Chassis Cab DRW 4WD	6.8L V-10	16,000 (all)
F-550 Super Chassis Cab DRW 4WD	6.4L V-8 TD	16,000 (all)
F-350 Crew Chassis Cab SRW 2WD	5.4L V-8	9,000 (e)
F-350 Crew Chassis Cab SRW 2WD	5.4L V-8	11,000 (f)
F-350 Crew Chassis Cab SRW 2WD	6.8L V-10	12,500 (f)
F-350 Crew Chassis Cab SRW 2WD	6.4L V-8 TD	12,500 (e)
F-350 Crew Chassis Cab SRW 4WD	5.4L V-8	8,500 (e)
F-350 Crew Chassis Cab SRW 4WD	5.4L V-8	10,500 (f)
F-350 Crew Chassis Cab SRW 4WD	6.8L V-10	12,500 (f)
F-350 Crew Chassis Cab SRW 4WD	6.4L V-8 TD	12,500 (e)
F-350 Crew Chassis Cab DRW 2WD	6.8L V-10	14,000 (f)
F-350 Crew Chassis Cab DRW 2WD	6.8L V-10	15,000 (g)
F-350 Crew Chassis Cab DRW 2WD	6.4L V-8 TD	15,000 (e/f)
F-350 Crew Chassis Cab DRW 4WD	6.8L V-10	13,500 (f)
F-350 Crew Chassis Cab DRW 4WD	6.8L V-10	15,000 (g)
F-350 Crew Chassis Cab DRW 4WD	6.4L V-8 TD	14,700 (e/f)
F-450 Crew Chassis Cab DRW 2WD	6.8L V-10	16,000 (all)
F-450 Crew Chassis Cab DRW 2WD	6.4L V-8 TD	16,000 (all)
F-450 Crew Chassis Cab DRW 4WD	6.8L V-10	16,000 (all)
F-450 Crew Chassis Cab DRW 4WD	6.4L V-8 TD	16,000 (all)
F-550 Crew Chassis Cab DRW 2WD	6.8L V-10	16,000 (all)
F-550 Crew Chassis Cab DRW 2WD	6.4L V-8 TD	16,000 (all)
F-550 Crew Chassis Cab DRW 4WD	6.8L V-10	16,000 (all)
F-550 Crew Chassis Cab DRW 4WD	6.4L V-8 TD	16,000 (all)

F-350/F-450/F-550 Super Duty Chassis Cab, Conventional Towing, Manual Transmission

F-350 Reg. Chassis Cab SRW 2WD	5.4L V-8	9,500 (e)
F-350 Reg. Chassis Cab SRW 2WD	5.4L V-8	10,500 (f)
F-350 Reg. Chassis Cab SRW 2WD	6.8L V-10	12,500 (f)
F-350 Reg. Chassis Cab SRW 2WD	6.4L V-8 TD	12,500 (e)
F-350 Reg. Chassis Cab SRW 4WD	5.4L V-8	8,100 (e)
F-350 Reg. Chassis Cab SRW 4WD	5.4L V-8	10,100 (f)
F-350 Reg. Chassis Cab SRW 4WD	6.8L V-10	12,500 (f)
F-350 Reg. Chassis Cab SRW 4WD	6.4L V-8 TD	12,500 (e)
F-350 Reg. Chassis Cab DRW 2WD	5.4L V-8	8,100 (e)
F-350 Reg. Chassis Cab DRW 2WD	5.4L V-8	10,600 (f)
F-350 Reg. Chassis Cab DRW 2WD	6.8L V-10	13,500 (f)
F-350 Reg. Chassis Cab DRW 2WD	6.8L V-10	15,000 (g)
F-350 Reg. Chassis Cab DRW 2WD	6.4L V-8 TD	15,000 (all)
F-350 Reg. Chassis Cab DRW 4WD	5.4L V-8	7,700 (e)
F-350 Reg. Chassis Cab DRW 4WD	5.4L V-8	10,200 (f)
F-350 Reg. Chassis Cab DRW 4WD	6.8L V-10	13,100 (f)
F-350 Reg. Chassis Cab DRW 4WD	6.8L V-10	15,000 (g)
F-350 Reg. Chassis Cab DRW 4WD	6.4L V-8 TD	15,000 (all)

F-450 Reg. Chassis Cab DRW 2WD	6.8L V-10	16,000 (all)
F-450 Reg. Chassis Cab DRW 2WD	6.4L V-8 TD	16,000 (all)
F-450 Reg. Chassis Cab DRW 4WD	6.8L V-10	16,000 (all)
F-450 Reg. Chassis Cab DRW 4WD	6.4L V-8 TD	16,000 (all)
F-550 Reg. Chassis Cab DRW 2WD	6.8L V-10	16,000 (all)
F-550 Reg. Chassis Cab DRW 2WD	6.4L V-8 TD	16,000 (all)
F-550 Reg. Chassis Cab DRW 4WD	6.8L V-10	16,000 (all)
F-550 Reg. Chassis Cab DRW 4WD	6.4L V-8 TD	16,000 (all)
F-350 Super Chassis Cab SRW 2WD	5.4L V-8	8,200 (e)
F-350 Super Chassis Cab SRW 2WD	5.4L V-8	10,200 (f)
F-350 Super Chassis Cab SRW 2WD	6.8L V-10	12,500 (f)
F-350 Super Chassis Cab SRW 2WD	6.4L V-8 TD	12,500 (e)
F-350 Super Chassis Cab SRW 4WD	5.4L V-8	7,700 (e)
F-350 Super Chassis Cab SRW 4WD	5.4L V-8	9,700 (f)
F-350 Super Chassis Cab SRW 4WD	6.8L V-10	12,500 (f)
F-350 Super Chassis Cab SRW 4WD	6.4L V-8 TD	12,500 (e)
F-350 Super Chassis Cab DRW 2WD	6.8L V-10	13,100 (f)
F-350 Super Chassis Cab DRW 2WD	6.8L V-10	15,000 (g)
F-350 Super Chassis Cab DRW 2WD	6.4L V-8 TD	15,000 (e/f)
F-350 Super Chassis Cab DRW 4WD	6.8L V-10	12,700 (f)
F-350 Super Chassis Cab DRW 4WD	6.8L V-10	14,700 (g)
F-350 Super Chassis Cab DRW 4WD	6.4L V-8 TD	14,900 (e/f)
F-450 Super Chassis Cab DRW 2WD	6.8L V-10	16,000 (all)
F-450 Super Chassis Cab DRW 2WD	6.4L V-8 TD	16,000 (all)
F-450 Super Chassis Cab DRW 4WD	6.8L V-10	16,000 (all)
F-450 Super Chassis Cab DRW 4WD	6.4L V-8 TD	16,000 (all)
F-550 Super Chassis Cab DRW 2WD	6.8L V-10	16,000 (all)
F-550 Super Chassis Cab DRW 2WD	6.4L V-8 TD	16,000 (all)
F-550 Super Chassis Cab DRW 4WD	6.8L V-10	16,000 (all)
F-550 Super Chassis Cab DRW 4WD	6.4L V-8 TD	16,000 (all)
F-350 Crew Chassis Cab SRW 2WD	5.4L V-8	8,000 (e)
F-350 Crew Chassis Cab SRW 2WD	5.4L V-8	10,000 (f)
F-350 Crew Chassis Cab SRW 2WD	6.8L V-10	12,500 (f)
F-350 Crew Chassis Cab SRW 2WD	6.4L V-8 TD	12,500 (e)
F-350 Crew Chassis Cab SRW 4WD	5.4L V-8	7,500 (e)
F-350 Crew Chassis Cab SRW 4WD	5.4L V-8	9,500 (f)
F-350 Crew Chassis Cab SRW 4WD	6.8L V-10	12,400 (f)
F-350 Crew Chassis Cab SRW 4WD	6.4L V-8 TD	12,500 (e)
F-350 Crew Chassis Cab DRW 2WD	6.8L V-10	13,000 (f)
F-350 Crew Chassis Cab DRW 2WD	6.8L V-10	15,000 (g)
F-350 Crew Chassis Cab DRW 2WD	6.4L V-8 TD	15,000 (all)
F-350 Crew Chassis Cab DRW 4WD	6.8L V-10	12,500 (f)
F-350 Crew Chassis Cab DRW 4WD	6.8L V-10	14,500 (g)
F-350 Crew Chassis Cab DRW 4WD	6.4L V-8 TD	14,700 (all)
F-450 Crew Chassis Cab DRW 2WD	6.8L V-10	16,000 (all)
F-450 Crew Chassis Cab DRW 2WD	6.4L V-8 TD	16,000 (all)
F-450 Crew Chassis Cab DRW 4WD	6.8L V-10	16,000 (all)
F-450 Crew Chassis Cab DRW 4WD	6.4L V-8 TD	16,000 (all)
F-550 Crew Chassis Cab DRW 2WD	6.8L V-10	16,000 (all)
F-550 Crew Chassis Cab DRW 2WD	6.4L V-8 TD	16,000 (all)
F-550 Crew Chassis Cab DRW 4WD	6.8L V-10	16,000 (all)
F-550 Crew Chassis Cab DRW 4WD	6.4L V-8 TD	16,000 (all)

F-350/F-450/F-550 Super Duty Chassis Cab, Fifth-Wheel Towing, Automatic Transmission

F-350 Reg. Chassis Cab SRW 2WD	5.4L V-8	9,500 (e)
F-350 Reg. Chassis Cab SRW 2WD	5.4L V-8	11,500 (f)
F-350 Reg. Chassis Cab SRW 2WD	6.8L V-10	14,400 (f)
F-350 Reg. Chassis Cab SRW 2WD	6.4L V-8 TD	15,600 (e)
F-350 Reg. Chassis Cab SRW 4WD	5.4L V-8	9,100 (e)
F-350 Reg. Chassis Cab SRW 4WD	5.4L V-8	11,100 (f)
F-350 Reg. Chassis Cab SRW 4WD	6.8L V-10	14,000 (f)
F-350 Reg. Chassis Cab SRW 4WD	6.4L V-8 TD	15,000 (e)
F-350 Reg. Chassis Cab DRW 2WD	5.4L V-8	9,600 (e)
F-350 Reg. Chassis Cab DRW 2WD	5.4L V-8	11,600 (f)
F-350 Reg. Chassis Cab DRW 2WD	6.8L V-10	14,500 (f)
F-350 Reg. Chassis Cab DRW 2WD	6.8L V-10	16,000 (g)
F-350 Reg. Chassis Cab DRW 2WD	6.4L V-8 TD	15,700 (e)
F-350 Reg. Chassis Cab DRW 2WD	6.4L V-8 TD	15,600 (f)
F-350 Reg. Chassis Cab DRW 4WD	5.4L V-8	9,200 (e)
F-350 Reg. Chassis Cab DRW 4WD	5.4L V-8	11,200 (f)
F-350 Reg. Chassis Cab DRW 4WD	6.8L V-10	14,100 (f)
F-350 Reg. Chassis Cab DRW 4WD	6.8L V-10	15,600 (g)
F-350 Reg. Chassis Cab DRW 4WD	6.4L V-8 TD	15,200 (all)
F-450 Reg. Chassis Cab DRW 2WD	6.8L V-10	18,500 (h)
F-450 Reg. Chassis Cab DRW 2WD	6.8L V-10	18,300 (i)
F-450 Reg. Chassis Cab DRW 2WD	6.4L V-8 TD	17,600 (g/h)
F-450 Reg. Chassis Cab DRW 2WD	6.4L V-8 TD	21,600 (h,t)
F-450 Reg. Chassis Cab DRW 4WD	6.8L V-10	18,100 (all)
F-450 Reg. Chassis Cab DRW 4WD	6.4L V-8 TD	17,300 (g/h)
F-450 Reg. Chassis Cab DRW 4WD	6.4L V-8 TD	21,300 (h,t)
F-550 Reg. Chassis Cab DRW 2WD	6.8L V-10	18,300 (all)
F-550 Reg. Chassis Cab DRW 2WD	6.4L V-8 TD	17,500 (g/h)
F-550 Reg. Chassis Cab DRW 2WD	6.4L V-8 TD	24,500 (h,t)
F-550 Reg. Chassis Cab DRW 4WD	6.8L V-10	18,000 (all)
F-550 Reg. Chassis Cab DRW 4WD	6.4L V-8 TD	17,100 (g/h)
F-550 Reg. Chassis Cab DRW 4WD	6.4L V-8 TD	24,100 (h,t)
F-350 Super Chassis Cab SRW 2WD	5.4L V-8	9,200 (e)
F-350 Super Chassis Cab SRW 2WD	5.4L V-8	11,200 (f)
F-350 Super Chassis Cab SRW 2WD	6.8L V-10	14,000 (f)
F-350 Super Chassis Cab SRW 2WD	6.4L V-8 TD	15,100 (e)
F-350 Super Chassis Cab SRW 4WD	5.4L V-8	8,700 (f)
F-350 Super Chassis Cab SRW 4WD	5.4L V-8	10,700 (f)
F-350 Super Chassis Cab SRW 4WD	6.8L V-10	13,600 (f)
F-350 Super Chassis Cab SRW 4WD	6.4L V-8 TD	14,700 (e)
F-350 Super Chassis Cab DRW 2WD	6.8L V-10	14,100 (f)
F-350 Super Chassis Cab DRW 2WD	6.8L V-10	15,600 (g)
F-350 Super Chassis Cab DRW 2WD	6.4L V-8 TD	15,300 (all)
F-350 Super Chassis Cab DRW 4WD	6.8L V-10	13,700 (f)
F-350 Super Chassis Cab DRW 4WD	6.8L V-10	15,200 (g)
F-350 Super Chassis Cab DRW 4WD	6.4L V-8 TD	14,900 (all)
F-450 Super Chassis Cab DRW 2WD	6.8L V-10	18,000 (all)
F-450 Super Chassis Cab DRW 2WD	6.4L V-8 TD	17,200 (g/h)
F-450 Super Chassis Cab DRW 2WD	6.4L V-8 TD	21,200 (h,t)
F-450 Super Chassis Cab DRW 4WD	6.8L V-10	17,700 (all)
F-450 Super Chassis Cab DRW 4WD	6.4L V-8 TD	16,800 (g/h)
F-450 Super Chassis Cab DRW 4WD	6.4L V-8 TD	20,800 (h,t)
F-550 Super Chassis Cab DRW 2WD	6.8L V-10	17,900 (all)

F-550 Super Chassis Cab DRW 2WD	6.4L V-8 TD	17,100 (g/h)
F-550 Super Chassis Cab DRW 2WD	6.4L V-8 TD	24,100 (h,t)
F-550 Super Chassis Cab DRW 4WD	6.8L V-10	17,500 (all)
F-550 Super Chassis Cab DRW 4WD	6.4L V-8 TD	16,700 (g/h)
F-550 Super Chassis Cab DRW 4WD	6.4L V-8 TD	23,700 (h,t)
F-350 Crew Chassis Cab SRW 2WD	5.4L V-8	9,000 (e)
F-350 Crew Chassis Cab SRW 2WD	5.4L V-8	11,000 (f)
F-350 Crew Chassis Cab SRW 2WD	6.8L V-10	13,900 (f)
F-350 Crew Chassis Cab SRW 2WD	6.4L V-8 TD	14,900 (e)
F-350 Crew Chassis Cab SRW 4WD	5.4L V-8	8,500 (e)
F-350 Crew Chassis Cab SRW 4WD	5.4L V-8	10,500 (f)
F-350 Crew Chassis Cab SRW 4WD	6.8L V-10	13,400 (f)
F-350 Crew Chassis Cab SRW 4WD	6.4L V-8 TD	14,400 (e)
F-350 Crew Chassis Cab DRW 2WD	6.8L V-10	14,000 (f)
F-350 Crew Chassis Cab DRW 2WD	6.8L V-10	15,500 (g)
F-350 Crew Chassis Cab DRW 2WD	6.4L V-8 TD	15,100 (all)
F-350 Crew Chassis Cab DRW 4WD	6.8L V-10	13,500 (f)
F-350 Crew Chassis Cab DRW 4WD	6.8L V-10	15,000 (g)
F-350 Crew Chassis Cab DRW 4WD	6.4L V-8 TD	14,700 (all)
F-450 Crew Chassis Cab DRW 2WD	6.8L V-10	17,900 (all)
F-450 Crew Chassis Cab DRW 2WD	6.4L V-8 TD	17,000 (g/h)
F-450 Crew Chassis Cab DRW 2WD	6.4L V-8 TD	21,000 (h,t)
F-450 Crew Chassis Cab DRW 4WD	6.8L V-10	17,500 (all)
F-450 Crew Chassis Cab DRW 4WD	6.4L V-8 TD	16,600 (g/h)
F-450 Crew Chassis Cab DRW 4WD	6.4L V-8 TD	20,600 (h,t)
F-550 Crew Chassis Cab DRW 2WD	6.8L V-10	17,700 (all)
F-550 Crew Chassis Cab DRW 2WD	6.4L V-8 TD	16,900 (g/h)
F-550 Crew Chassis Cab DRW 2WD	6.4L V-8 TD	23,900 (h,t)
F-550 Crew Chassis Cab DRW 4WD	6.8L V-10	17,400 (all)
F-550 Crew Chassis Cab DRW 4WD	6.4L V-8 TD	16,500 (g/h)
F-550 Crew Chassis Cab DRW 4WD	6.4L V-8 TD	23,500 (h,t)

F-350/F-450/F-550 Super Duty Chassis Cab, Fifth-Wheel Towing, Manual Transmission

F-350 Reg. Chassis Cab SRW 2WD	5.4L V-8	8,500 (e)
F-350 Reg. Chassis Cab SRW 2WD	5.4L V-8	10,500 (f)
F-350 Reg. Chassis Cab SRW 2WD	6.8L V-10	13,400 (f)
F-350 Reg. Chassis Cab SRW 2WD	6.4L V-8 TD	15,600 (e)
F-350 Reg. Chassis Cab SRW 4WD	5.4L V-8	8,100 (e)
F-350 Reg. Chassis Cab SRW 4WD	5.4L V-8	10,100 (f)
F-350 Reg. Chassis Cab SRW 4WD	6.8L V-10	13,000 (f)
F-350 Reg. Chassis Cab SRW 4WD	6.4L V-8 TD	15,000 (e)
F-350 Reg. Chassis Cab DRW 2WD	5.4L V-8	8,100 (e)
F-350 Reg. Chassis Cab DRW 2WD	5.4L V-8	10,600 (f)
F-350 Reg. Chassis Cab DRW 2WD	6.8L V-10	13,500 (f)
F-350 Reg. Chassis Cab DRW 2WD	6.8L V-10	15,500 (g)
F-350 Reg. Chassis Cab DRW 2WD	6.4L V-8 TD	15,700 (all)
F-350 Reg. Chassis Cab DRW 4WD	5.4L V-8	7,700 (e)
F-350 Reg. Chassis Cab DRW 4WD	5.4L V-8	10,200 (f)
F-350 Reg. Chassis Cab DRW 4WD	6.8L V-10	13,100 (f)
F-350 Reg. Chassis Cab DRW 4WD	6.8L V-10	15,100 (g)
F-350 Reg. Chassis Cab DRW 4WD	6.4L V-8 TD	15,200 (all)
F-450 Reg. Chassis Cab DRW 2WD	6.8L V-10	18,500 (all)
F-450 Reg. Chassis Cab DRW 2WD	6.4L V-8 TD	17,600 (g/h)
F-450 Reg. Chassis Cab DRW 2WD	6.4L V-8 TD	19,600 (h,t)

F-450 Reg. Chassis Cab DRW 4WD	6.8L V-10	18,100 (all)
F-450 Reg. Chassis Cab DRW 4WD	6.4L V-8 TD	17,300 (g/h)
F-450 Reg. Chassis Cab DRW 4WD	6.4L V-8 TD	19,300 (h,t)
F-550 Reg. Chassis Cab DRW 2WD	6.8L V-10	18,300 (all)
F-550 Reg. Chassis Cab DRW 2WD	6.4L V-8 TD	17,500 (g/h)
F-550 Reg. Chassis Cab DRW 2WD	6.4L V-8 TD	19,500 (h,t)
F-550 Reg. Chassis Cab DRW 4WD	6.8L V-10	18,000 (all)
F-550 Reg. Chassis Cab DRW 4WD	6.4L V-8 TD	17,100 (g/h)
F-550 Reg. Chassis Cab DRW 4WD	6.4L V-8 TD	19,100 (h,t)
F-350 Super Chassis Cab SRW 2WD	5.4L V-8	8,200 (e)
F-350 Super Chassis Cab SRW 2WD	5.4L V-8	10,200 (f)
F-350 Super Chassis Cab SRW 2WD	6.8L V-10	13,000 (f)
F-350 Super Chassis Cab SRW 2WD	6.4L V-8 TD	15,100 (e)
F-350 Super Chassis Cab SRW 4WD	5.4L V-8	7,700 (e)
F-350 Super Chassis Cab SRW 4WD	5.4L V-8	9,700 (f)
F-350 Super Chassis Cab SRW 4WD	6.8L V-10	12,600 (f)
F-350 Super Chassis Cab SRW 4WD	6.4L V-8 TD	14,700 (e)
F-350 Super Chassis Cab DRW 2WD	6.8L V-10	13,100 (f)
F-350 Super Chassis Cab DRW 2WD	6.8L V-10	15,100 (g)
F-350 Super Chassis Cab DRW 2WD	6.4L V-8 TD	15,300 (all)
F-350 Super Chassis Cab DRW 4WD	6.8L V-10	12,700 (f)
F-350 Super Chassis Cab DRW 4WD	6.8L V-10	14,700 (g)
F-350 Super Chassis Cab DRW 4WD	6.4L V-8 TD	14,900 (all)
F-450 Super Chassis Cab DRW 2WD	6.8L V-10	18,000 (all)
F-450 Super Chassis Cab DRW 2WD	6.4L V-8 TD	17,200 (g/h)
F-450 Super Chassis Cab DRW 2WD	6.4L V-8 TD	19,200 (h,t)
F-450 Super Chassis Cab DRW 4WD	6.8L V-10	17,700 (all)
F-450 Super Chassis Cab DRW 4WD	6.4L V-8 TD	16,800 (g/h)
F-450 Super Chassis Cab DRW 4WD	6.4L V-8 TD	18,800 (h,t)
F-550 Super Chassis Cab DRW 2WD	6.8L V-10	17,900 (all)
F-550 Super Chassis Cab DRW 2WD	6.4L V-8 TD	17,100 (g/h)
F-550 Super Chassis Cab DRW 2WD	6.4L V-8 TD	19,100 (h,t)
F-550 Super Chassis Cab DRW 4WD	6.8L V-10	17,500 (all)
F-550 Super Chassis Cab DRW 4WD	6.4L V-8 TD	16,700 (g/h)
F-550 Super Chassis Cab DRW 4WD	6.4L V-8 TD	18,700 (h,t)
F-350 Crew Chassis Cab SRW 2WD	5.4L V-8	8,000 (e)
F-350 Crew Chassis Cab SRW 2WD	5.4L V-8	10,000 (f)
F-350 Crew Chassis Cab SRW 2WD	6.8L V-10	12,900 (f)
F-350 Crew Chassis Cab SRW 2WD	6.4L V-8 TD	14,900 (e)
F-350 Crew Chassis Cab SRW 4WD	5.4L V-8	7,500 (e)
F-350 Crew Chassis Cab SRW 4WD	5.4L V-8	9,500 (f)
F-350 Crew Chassis Cab SRW 4WD	6.8L V-10	12,400 (f)
F-350 Crew Chassis Cab SRW 4WD	6.4L V-8 TD	14,400 (e)
F-350 Crew Chassis Cab DRW 2WD	6.8L V-10	13,000 (f)
F-350 Crew Chassis Cab DRW 2WD	6.8L V-10	15,000 (g)
F-350 Crew Chassis Cab DRW 2WD	6.4L V-8 TD	15,100 (all)
F-350 Crew Chassis Cab DRW 4WD	6.8L V-10	12,500 (f)
F-350 Crew Chassis Cab DRW 4WD	6.8L V-10	14,500 (g)
F-350 Crew Chassis Cab DRW 4WD	6.4L V-8 TD	14,700 (all)
F-450 Crew Chassis Cab DRW 2WD	6.8L V-10	17,900 (all)
F-450 Crew Chassis Cab DRW 2WD	6.4L V-8 TD	17,000 (g/h)
F-450 Crew Chassis Cab DRW 2WD	6.4L V-8 TD	19,000 (h,t)
F-450 Crew Chassis Cab DRW 4WD	6.8L V-10	17,500 (all)
F-450 Crew Chassis Cab DRW 4WD	6.4L V-8 TD	16,600 (g/h)
F-450 Crew Chassis Cab DRW 4WD	6.4L V-8 TD	18,600 (h,t)

F-550 Crew Chassis Cab DRW 2WD	6.8L V-10	17,700 (all)
F-550 Crew Chassis Cab DRW 2WD	6.4L V-8 TD	16,900 (g/h)
F-550 Crew Chassis Cab DRW 2WD	6.4L V-8 TD	18,900 (h,t)
F-550 Crew Chassis Cab DRW 4WD	6.8L V-10	17,400 (all)
F-550 Crew Chassis Cab DRW 4WD	6.4L V-8 TD	16,500 (h)
F-550 Crew Chassis Cab DRW 4WD	6.4L V-8 TD	18,500 (h,t)

Key to Ford Section

*F-250/350 models with 5.4-liter V-8 and manual transmission are rated to tow 1,000 lb less. Ratings for 6.8-liter V-10 and 6.4-liter V-8 turbodiesel models are the same as automatic-transmission ratings.
 a = Automatic Transmission
 a4 = Automatic Transmission, four speed
 a6 = Auto Transmission, six speed
 m = Manual Transmission
 b = 3.15:1 axle ratio
 c = 3.31:1 axle ratio
 d = 3.55:1 axle ratio
 e = 3.73:1 axle ratio
 f = 4.10:1 axle ratio
 g = 4.30:1 axle ratio
 all = All available gear ratios apply
 AWD = All Wheel Drive
 CC = Crew Cab
 SC = SuperCab
 LB = 8-foot bed
 Shortbed = 5½-foot bed
 Std. Bed = 6½-foot bed
 SRW = Single Rear Wheel
 DRW = Dual Rear Wheels
 2V = Two valves per cylinder
 3V = Three valves per cylinder
 TD = Turbodiesel
 t = Tow package required

HONDA

Odyssey	3.5L V-6	3,500
Pilot 2WD	3.5L V-6	3,500
Pilot 4WD	3.5L V-6	4,500
Ridgeline	3.5L V-6	5,000

HUMMER

H2	6.2L V-8	8,200
H2 SUT	6.2L V-8	8,200
H3	3.7L I-5	4,500 (a)
H3	3.7L I-5	3,000 (m)
H3 Alpha	5.3L V-8	6,000
H3T	3.7L I-5	4,400 (a)
H3T	3.7L I-5	2,900 (m)
H3T Alpha	5.3L V-8	5,900

a = Automatic transmission

m = Manual transmission

HYUNDAI

Entourage	3.8L V-6	3,500
Santa Fe 2WD	2.7L V-6	2,000 (x)
Santa Fe 2WD	3.5L V-6	2,000 (x)
Santa Fe 4WD	2.7L V-6	2,000 (x)
Santa Fe 4WD	3.5L V-6	2,000 (x)
Tucson	2.7L V-6	2,000 (x)
Veracruz (all)	3.8L V-6	3,500 (t)

x = Trailer brakes required

t = Tow package required

INFINITI

QX56 2WD	5.6L V-8	9,000
QX56 AWD	5.6L V-8	8,900
FX35	3.5L V-6	2,000
FX50	5.0L V-8	3,500

JEEP

Commander 2WD	3.7L V-6	3,500
Commander 2WD	4.7L V-8	6,500
Commander 2WD	5.7L V-8	7,400
Commander 4WD	3.7L V-6	3,500
Commander 4WD	4.7L V-8	6,500
Commander 4WD	5.7L V-8	7,200
Grand Cherokee 2WD	3.0L TD V-6	7,400
Grand Cherokee 4WD	3.0L TD V-6	7,200
Grand Cherokee 2WD	3.7L V-6	3,500
Grand Cherokee 4WD	3.7L V-6	3,500
Grand Cherokee 2WD	4.7L V-8	6,500
Grand Cherokee 4WD	4.7L V-8	6,500
Grand Cherokee 2WD	5.7L V-8	7,400
Grand Cherokee 4WD	5.7L V-8	7,200
Grand Cherokee SRT8	6.1L V-8	3,500
Liberty 2WD	3.7L V-6	3,500 (m,t)
Liberty 2WD	3.7L V-6	5,000 (a,t)
Liberty 4WD	3.7L V-6	3,500 (m,t)
Liberty 4WD	3.7L V-6	5,000 (a,t)
Wrangler	3.8L V-6	2,000
Wrangler Unlimited	3.8L V-6	3,500
Wrangler Unlimited Rubicon	3.8L V-6	3,500

a = Automatic transmission

m = Manual transmission

KIA

Borrego	3.8L V-6	5,000
Borrego	4.6L V-8	7,500
Sedona	3.8L V-6	3,500
Sorento	3.3L V-6	3,500
Sorento	3.8L V-6	5,000
Sportage	2.7L V-6	2,000

LAND ROVER

Land Rover LR2	3.2L I-6	3,500 (x)
Land Rover LR3	4.4L V-8	7,716 (x)
Range Rover	4.2L V-8	7,716 (x)
Range Rover	4.4L V-8	7,716 (x)
Range Rover Sport	4.2L V-8 SC	7,716 (x)
Range Rover Sport	4.4L V-8 SC	7,716 (x)

x = Trailer brakes required

LEXUS

RX 350	3.5L V-6	3,500
RX 400h (hybrid)	3.3L V-6	3,500
GX 470	4.7L V-8	6,500
LX 570	5.7L V-8	8,500

LINCOLN-MERCURY

Mariner	2.5L I-4	3,500 (t)
Mariner	3.0L V-6	3,500 (t)
Mountaineer 2WD 5 pass.	4.0L V-6	5,295
Mountaineer 2WD 5 pass.	4.6L V-8	7,220
Mountaineer AWD 5 pass.	4.0L V-6	5,000
Mountaineer AWD 5 pass.	4.6L V-8	7,055

Mountaineer 2WD 7 pass.	4.0L V-6	5,205
Mountaineer 2WD 7 pass.	4.6L V-8	7,135
Mountaineer AWD 7 pass.	4.0L V-6	5,000
Mountaineer AWD 7 pass.	4.6L V-8	6,970
Navigator 2WD	5.4L V-8	8,950
Navigator L 2WD	5.4L V-8	8,850
Navigator 4WD	5.4L V-8	8,750
Navigator L 4WD	5.4L V-8	8,475

t = Tow package required

MAZDA

B-2300 Reg Cab 2WD	2.3L I-4	2,260 (a,i)
B-4000 4WD	4.0L V-6	3,140 (m,i)
B-4000 4WD	4.0L V-6	5,600 (a,i)
CX7 (all)	2.3L TC	2,000 (a)
CX9 (all)	3.7L V-6	3,500 (a,t)
Tribute	3.0L V-6	3,500 (a,t)

a = Automatic transmission

m = Manual transmission

i = 4.10:1 axle ratio

t = Towing package required

MERCEDES-BENZ

G550	5.5L V-8	7,000
G55 AMG	5.4L V-8	7,000
GL320 BlueTEC	3.0L TD V-6	7,500
GL450	4.6L V-8	7,500
GL550	5.5L V-8	7,500
ML320 BlueTEC	3.0L TD V-6	7,200
ML350	3.5L V-6	7,200
ML550	5.5L V-8	7,200
ML63 AMG	6.3L V-8	7,200

MITSUBISHI

Outlander 2WD	3.0L V-6	2,000
Outlander 4WD	3.0L V-6	3,500
Endeavor	3.8L V-6	3,500
Raider Dbl. Cab 2WD	3.7L V-6	4,050 (a4,f)
Raider Dbl. Cab 2WD	3.7L V-6	4,350 (a4,h)
Raider Dbl. Cab 4WD	3.7L V-6	3,850 (a4,f)
Raider Dbl. Cab 4WD	3.7L V-6	4,150 (a4,h)

a4 = Automatic transmission, four speed

f = 3.55:1 axle ratio

h = 3.92:1 axle ratio

NISSAN

Armada 2WD	5.6L V-8	9,100
Armada 4WD	5.6L V-8	9,000
Frontier KC XE 2WD	2.5L I-4	3,500
Frontier KC SE, LE, Nismo 2WD	4.0L V-6	6,500
Frontier KC SE, LE, Nismo 4WD	4.0L V-6	6,300
Frontier CC SE, LE, Nismo 2WD	4.0L V-6	6,300
Frontier CC SE, LE, Nismo 4WD	4.0L V-6	6,100
Murano	3.5L V-6	3,500
Pathfinder	4.0L V-6	6,000
Pathfinder	5.6L V-8	7,000
Quest	3.5L V-6	3,500
Titan KC 2WD	5.6L V-8	9,500

Titan KC 4WD	5.6L V-8	9,400
Titan CC 2WD	5.6L V-8	9,400
Titan CC 4WD	5.6L V-8	9,400
Titan Longbed CC 2WD	5.6L V-8	9,300
Titan Longbed CC 4WD	5.6L V-8	9,100
Xterra	4.0L V-6	5,000

PONTIAC

Torrent	3.4L V-6	3,500
---------	----------	-------

PORSCHE

Cayenne	All	7,716
---------	-----	-------

SAAB

9-3 (all)	(all)	3,500
9-5 (all)	(all)	3,500
9-7X	4.2L I-6	5,600
9-7X	5.3L V-8	6,500
9-7X	6.0L V-8	6,500

SATURN

VUE	All V-6	3,500
Outlook	3.6L V-6	4,500

SUBARU

Tribeca	3.6L H6	3500 (t)
Forester	2.5L H4	2400 (x)
Outback	2.5L H4	2,700
Outback	3.0L H6	3,000

t = Tow package required

x = Trailer brakes required

SUZUKI

Grand Vitara	2.4L I-4	3,000
Grand Vitara	3.2L V-6	3,000
XL7	3.6L V-6	3,500

TOYOTA

4Runner 2WD	4.0L V-6	5,000
4Runner 4WD	4.0L V-6	5,000
4Runner 2WD	4.7L V-8	7,300
4Runner 4WD	4.7L V-8	7,000
FJ Cruiser	4.0L V-6	5,000
Highlander	3.5L V-6	2,000
Highlander	3.5L V-6	5,000 (t)
Highlander Hybrid	3.3L V-6	3,500
Land Cruiser	5.7L V-8	8,500
RAV4	3.5L V-6	2,000
RAV4	3.5L V-6	3,500 (t)
Sienna	3.5L V-6	3,500
Sequoia 2WD SR5	4.7L V-8	6,300
Sequoia 2WD Ltd	4.7L V-8	6,200
Sequoia 4WD SR5	4.7L V-8	6,000
Sequoia 4WD Ltd	4.7L V-8	5,600
Sequoia 2WD SR5	5.7L V-8	8,300
Sequoia 2WD SR5	5.7L V-8	10,000 (t)

Sequoia 2WD Ltd	5.7L V-8	8,200
Sequoia 2WD Ltd	5.7L V-8	9,500 (t)
Sequoia 2WD Platinum	5.7L V-8	8,100
Sequoia 2WD Platinum	5.7L V-8	9,100 (t)
Sequoia 4WD SR5	5.7L V-8	8,000
Sequoia 4WD SR5	5.7L V-8	9,600 (t)
Sequoia 4WD Ltd	5.7L V-8	7,900
Sequoia 4WD Ltd	5.7L V-8	9,100 (t)
Sequoia 2WD Platinum	5.7L V-8	7,800
Sequoia 2WD Platinum	5.7L V-8	8,800 (t)
Tacoma Reg. Cab	2.7L I-4	3,500
Tacoma Access Cab/X-Runner	2.7L I-4	3,500
Tacoma Access Cab 2WD/4WD	4.0L V-6	5,000
Tacoma Access Cab 2WD/4WD	4.0L V-6	6,500 (t)
Tacoma Double Cab 2WD/4WD	4.0L V-6	5,000
Tacoma Double Cab 2WD/4WD	4.0L V-6	6,500 (t)
Tundra Reg. Cab Shortbed	4.0L V-6	5,100
Tundra Reg. Cab Longbed	4.0L V-6	5,000
Tundra Double Cab Shortbed 2WD	4.0L V-6	4,800
Tundra Reg. Cab Shortbed 2WD	4.7L V-8	7,000
Tundra Reg. Cab Shortbed 2WD	4.7L V-8	8,500 (t)
Tundra Reg. Cab Shortbed 4WD	4.7L V-8	6,900
Tundra Reg. Cab Shortbed 4WD	4.7L V-8	8,400
Tundra Reg. Cab Longbed 2WD	4.7L V-8	6,900
Tundra Reg. Cab Longbed 2WD	4.7L V-8	8,400 (t)
Tundra Reg. Cab Longbed 2WD	5.7L V-8	10,500 (t)
Tundra Reg. Cab Longbed 4WD	4.7L V-8	6,600
Tundra Reg. Cab Longbed 4WD	4.7L V-8	8,100 (t)
Tundra Reg. Cab Longbed 4WD	5.7L V-8	10,800 (t)
Tundra Double Cab Shortbed 2WD	4.7L V-8	7,000
Tundra Double Cab Shortbed 2WD	4.7L V-8	8,500 (t)
Tundra Double Cab Shortbed 4WD	4.7L V-8	6,700
Tundra Double Cab Shortbed 4WD	4.7L V-8	8,200 (t)

Tundra Double Cab Longbed 2WD	4.7L V-8	6,900
Tundra Double Cab Longbed 2WD	4.7L V-8	8,400 (t)
Tundra Double Cab Longbed 4WD	4.7L V-8	6,600
Tundra Double Cab Longbed 4WD	4.7L V-8	8,100
Tundra Reg. Cab 2WD	5.7L V-8	10,800
Tundra Reg. Cab 4WD	5.7L V-8	10,400
Tundra Double Cab Shortbed 2WD	5.7L V-8	8,600
Tundra Double Cab Shortbed 2WD	5.7L V-8	10,600t
Tundra Double Cab Longbed 2WD	5.7L V-8	10,500t
Tundra Double Cab Shortbed 4WD	5.7L V-8	8,300
Tundra Double Cab Shortbed 4WD	5.7L V-8	10,300t
Tundra Double Cab Longbed 4WD	5.7L V-8	10,200
Tundra CrewMax 2WD	4.7L V-8	7,700 (t)
Tundra CrewMax 4WD	4.7L V-8	8,000 (t)
Tundra CrewMax 2WD	5.7L V-8	10,400
Tundra CrewMax 4WD	5.7L V-8	10,100

t = Tow package required

VOLKSWAGEN

Tiguan	2.0L I-4TC	2,200
Touareg	All	7,716

VOLVO

C30	2.5L I-5TC	2,000
S40	2.4L I-5	2,000
S40	2.5L I-5TC	2,000
S60	2.5L I-5	3,300
S80	All	3,300
V50	2.4L I-5	2,000
V50	2.5L I-5TC	2,000
V70	3.2L I-6	3,300
XC70	3.2L I-6	3,970
XC90 AWD	4.4L V-8	4,960

Reach 3 MILLION shoppers today!

RVSearch.com is your one-stop site for buying and selling RVs.

www.RVSearch.com

1-800-SHOP-4-RV



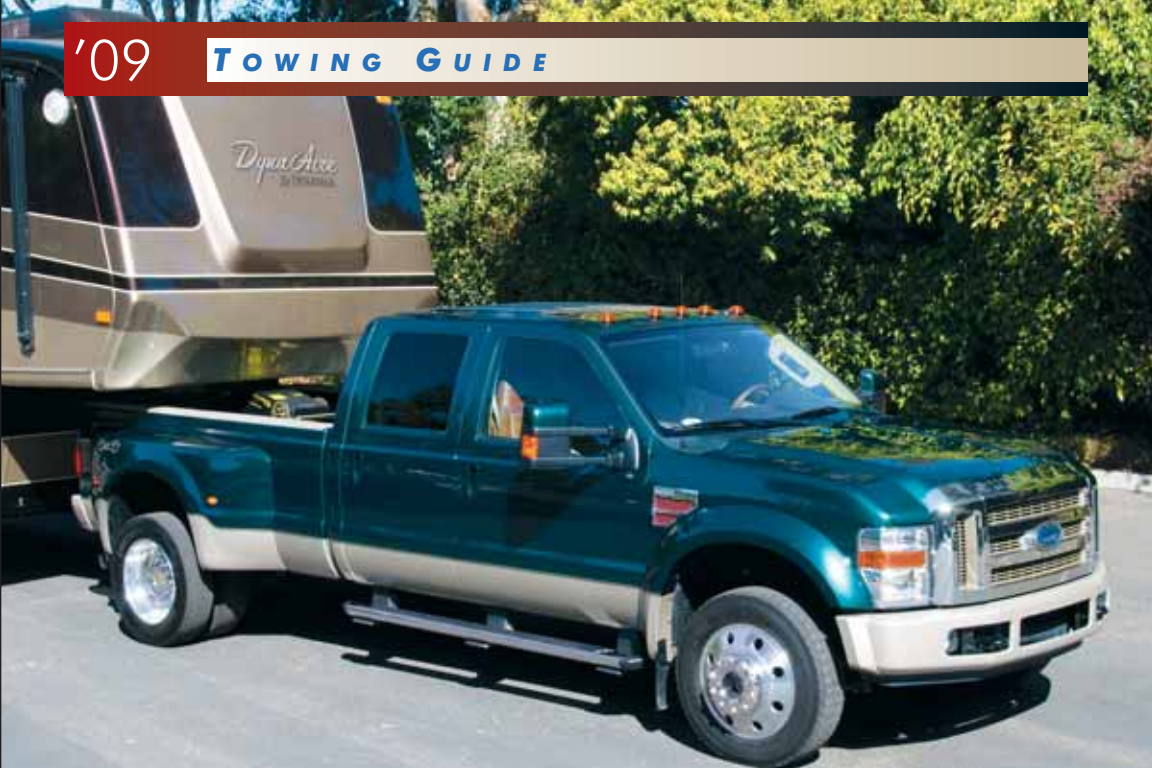

Hitching Up

Selecting and maintaining the proper hardware are key to a pleasant towing experience

BY JOEL DONALDSON

The process of buying a new travel trailer or fifth-wheel, like buying an automobile or some other complex, big-ticket item, is full of choices. What is supposed to be an enjoyable experience is filled with such tasks as negotiating a price, arranging financing, settling on a fair trade-in value for your old rig and choosing insurance, floorplans, décor schemes and optional equipment. However, one of the most important choices may be considered an afterthought: namely, choosing the proper trailer hitch.

Fortunately, selecting the right hitch isn't difficult, nor is its installation — after locating a competent hitch shop, that is. Maintaining proper adjustment of the hitch on an ongoing basis is the real challenge, and it has a large bearing on the safety and enjoyment of trailer towing.

Trailers are available in two different designs — a travel trailer that's coupled to the rear of the tow vehicle by a conventional hitch ball, and a fifth-wheel trailer that utilizes a fifth-wheel (or gooseneck) hitch mounted in the truck bed, cen-

tered over the rear axle. The hitching methods are as different as the trailers and require specific knowledge by the installer and trailer owner.

Conventional Hitches

All hitches are rated by their respective manufacturers to safely handle up to a specific gross vehicle weight rating (gvwr), which is the weight of the trailer with full water and LP-gas cylinders — and all supplies aboard. Several weight classes exist for hitches designed for towing conventional travel trailers.

Weight-carrying hitches are intended for lighter trailers because the entire trailer's hitch weight is carried on the ball and transferred to the rear axle of the tow vehicle, whereas load-distributing hitches are designed to distribute the trailer's hitch weight to all axles of the tow vehicle and trailer, making larger, heavier trailers with considerably higher hitch weights towable without destabilizing the tow vehicle.

A travel trailer with ideal weight distribution

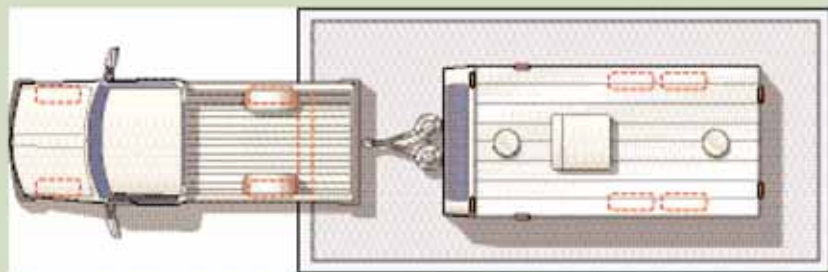

To determine hitch weight, first get a reading on axle weight (above), then unhitch the trailer for a total weight reading and then subtract the two.



Using a weight-carrying hitch

Using a weight-distributing hitch

A weight-distributing hitch distributes weight to all axles of the tow vehicle and the trailer.

will have a minimum hitch weight of about 10 percent of the gross weight, and the maximum can range upward to 15 percent — providing it does not violate the rating of the hitch.

Except for the lightest folding trailers, hitches

rated Class II and higher are used for recreational towing, and they use a receiver bolted to the tow vehicle's frame. The hitch receiver — which may have box dimensions of 1½ inches square, 2 inches square or 2½ inches square, with larger boxes for higher load ratings — accepts a slide-in ball mount (or draw bar), which is secured with a pin.

Besides serving as the trailer/receiver attachment point, the ball mount also is used in varying heights (known as “drop”) to couple the trailer in a level fashion (frame parallel to the road surface), which is desirable for best stability and trailer-brake performance. Some ball mounts are fixed, while others are adjustable.

Ball mounts used for weight-carrying hitches are quite different than those used for load distributing. Need for weight-distributing hitches

Weight Carrying

- Class I 200-lb HW, 2,000-lb gwwr
- Class II 350-lb HW, 3,500-lb gwwr
- Class III 500-lb HW, 5,000-lb gwwr
- Class IV 750-lb HW, 7,500-lb gwwr
- Class V 1,200-lb HW, 12,000-lb gwwr

Weight-Distributing

- Class IV 1,200-lb HW, 12,000-lb gwwr
- Class V 1,400-lb HW, 14,000-lb gwwr

HW=Hitch Weight



Blue Ox hitch



Equal-i-zer hitch

varies with tow-vehicle type and trailer weight. A trailer with 350 pounds of hitch weight may present no challenge for a stiffly sprung, long-wheelbase $\frac{3}{4}$ -ton pickup, while it may destabilize a softly sprung compact SUV. In general, a weight-distributing hitch will improve stability in most situations because weight resting on a hitch ball (when a weight-carrying hitch is used) loads the rear axle excessively by placing all of the hitch weight on that axle in addition to weight that is transferred from the front axle to the rear in a see-saw lever action.

Because many receivers are usable in either weight-carrying or weight-distributing configurations — depending on the ball mount — the receiver's manufacturer may list both ratings.

Weight-distributing hitches should be used in many weight situations of Class II, and in most situations of Class III and above. Unlike their weight-carrying counterparts, these hitches typically use a much heavier ball mount (that's adjustable in height), plus a pair of spring bars that provide the leverage needed to distribute weight fore and aft.

Adjusting the Hitch

After having a load-distributing hitch of proper weight rating installed, owners may take the rest for granted, which can be a costly error because an improperly adjusted load-distributing hitch can contribute to trailer sway, which is a very undesirable handling trait. For more detailed information about weight-distributing hitches, see the article, "Tending with Bars" in the February 2008 issue of *Trailer Life*.

The keys to happy towing are proper ball height and proper load (tension) on the spring bars. When all aspects are correct, the tow vehicle and the trailer are at proper ride height, which in most cases is level. One exception will be described later. Proper hitch adjustment helps prevent rear-axle overloading and improves braking and steering response.

Evaluating the proper adjustment of a load-distributing hitch is relatively simple: The tow vehicle should maintain the same attitude before hitching that it does after hitching, measured at reference points at the front and rear bumpers. If it is level before hitching, it should be level afterward, although slightly lower due to the addition of hitch weight. Level attitude means adequate load is placed on the spring bars to distribute portions of the hitch weight equally to the front and rear axles. If the rear of the tow vehicle sags after hitching, then the spring-bar loading isn't adequate.

The exception to level attitude: If the tow vehicle is a stiffly sprung pickup and the rear of the truck is higher than the front, that attitude should be maintained after hitching. Such trucks often will carry heavy loads without the need for weight-distributing hitches and without sagging. But care must be exercised here. Although the truck may not look like it's sagging visually, the hitch weight carried by the rear axle may still create an unstable situation.

If the trailer is not level after spring bars have been adjusted to create the proper tow-vehicle attitude, the ball height should be corrected.

Trailer sway can be a problem if trailer balance or hitch adjustment are not correct because the trailer has steering leverage on the tow vehicle by virtue of being connected to the tow vehicle 3 or 4 feet behind the rear axle. With correct hitching, trailer balance may be a problem if the hitch weight is less than 10 percent of gross weight. It should be more than 10 percent (we recommend a minimum of 11 percent) for best stability.

Even with a well-balanced trailer and a properly adjusted hitch, use of a sway-control device is highly recommended. Often called sway bars (not to be confused with anti-roll bars fitted to axles of tow vehicles), sway-control devices are designed to damp rotation of the coupler on the hitch ball. They improve the handling characteristics of the trailer/tow vehicle combination whether the hitch



PullRite 70-Degree hitch



Draw-Tite W-D hitch

To improve rear-view visibility and to aid in hitching up, the available Reverse Camera System in the Ford F-150 uses a camera mounted in the tailgate (below, right) to produce a real-time visual display in the interior rearview mirror (pictured). When ordered with the available advanced Voice-Activated Navigation System, the visual is displayed on the Navigation System's screen.



method is weight-carrying or weight-distributing.

Sway-control devices are available in two different configurations, the most popular of which is one that employs a steel bar, attached to the ball mount, that is encased in a rail or tube attached to the trailer A-frame. Inside the rail or tube is friction material that is clamped against the steel bar. Any pivoting of the trailer coupler on the bar causes the bar to slide within the rail, creating drag and damping sway. On larger trailers, it's often possible to use a pair of friction-type units for additional sway control.

One popular hitch, the Equal-i-zer, includes a friction feature in the hitch design in that the tips of spring bars create friction on trailer-frame brackets. Cam-type sway units work by modifying the operation of the spring bars on a weight-distributing hitch. As the trailer turns, a cam increases the tension on one of the bars, creating a force that tends to pull the trailer back into a straight line. The harder the trailer turns, the stronger this self-centering force becomes. Since this scheme relies on spring-bar tension, it's generally most effective on trailers with relatively high hitch weights (e.g., trailers requiring considerable spring-bar tension).

The Hensley Arrow and Pulliam Enterprises' PullRite hitch systems offer different approaches to controlling sway.

The Hensley unit prevents sway through use of trapezoidal hitch linkages that make the tow vehicle and trailer act as a single unit, with no pivoting of the coupler on the ball unless the tow vehicle turns. Thus, during typical highway travel the tow vehicle and trailer are connected as non-articulated vehicles, and tend to function as a single unit. Even so, there is no restriction on the tow vehicle's capability for turns.

The PullRite, in effect, moves the hitch pivot point to a location immediately aft of the tow vehicle's rear axle, dramatically reducing the leverage the trailer can exert on the tow vehicle.



Fifth-Wheel Hitches

Fifth-wheel towing is a different story altogether. The trailer's kingpin serves as the pivot point for the fifth-wheel hitch, which is centered slightly ahead or above the truck's rear axle. The trailer's kingpin slides into the hitch head, where it is secured by latching jaws or some other mechanism. This head is attached to a support base, which transfers the towing forces to the truck frame.

The design prevents the trailer from having any steering effect on the tow vehicle, and is what gives fifth-wheel trailers such good road manners. Wind gusts and road irregularities have little to no effect on tow-vehicle stability.

Most hitches are secured to the bed with a pair of mounting rails, while other underbed systems leave the truck bed flat after the hitch is removed. Most removable systems use permanently mounted rails with pins to secure the hitch head. The underbed style of fifth-wheel-hitch mount is completely different in that the entire hitch mechanism is removed by simply pulling a lever in the wheel well. PullRite also uses an underbed system with removable connection pins. Some systems, where the hitch saddle and support base can be removed separately, make it easier on the back when lifting the hardware.

Many fifth-wheel heads are mounted so they tilt fore and aft; however, having only the fore-and-aft pivot restricts side-to-side movement.

Some hitches have heads that pivot in multiple directions, allowing the pinbox to move in



Hitch removal while the fifth-wheel is in storage is a common problem. Hensley Manufacturing solves this dilemma with its BD3 Air-Ride hitch, which allows for full use of the pickup bed. First, the heavy-duty hitch head is easily removed. Next, the main unit is lifted from the truck rails and ready for storage.

any direction with respect to the pickup, while still maintaining a tight mechanical connection. This also makes it easier to hitch or unhitch the trailer on uneven ground.

Another strategy for improving trailer-truck flexibility involves the use of air springs as part of the hitch design. Typically, the hitch is suspended on multiple bladder-type air bags, which support most of the trailer's kingpin weight. Aside from providing considerable articulation, these bags are also capable of smoothing out much of the road shocks and vibration that would otherwise be transmitted from the trailer to the tow vehicle. Adjustments to the system can be accomplished by varying the amount of air pressure in the bags.

Other air-suspension hitches use a hinged pivot arm and a single airbag setup to provide truck-to-trailer impact damping while the hitch head mechanism provides the side- and for/aft head tilting.

Shortbed pickups are now more popular than ever, particularly among extended-cab models. However, a short bed often causes complications when using the truck for towing a fifth-wheel because the proper hitch-mounting location is far enough forward to cause trailer-to-cab collisions during sharp turns. Installing an extended pinbox provides a workable solution with smaller trailers with modest pin weights; however, owners should first check with the pinbox manufacturer before adding any extension.

For larger units, one solution is a conventional hitch that can be manually unlocked and moved aft on a special set of rails before making tight turns. PullRite offers a hitch that performs this motion automatically, returning to the forward-towing position after the turn is completed. Rearward travel can be as much as 22 inches for some models, which is generally adequate for

accommodating 102-inch-wide trailers. Turns as tight as 90 degrees are possible in some cases.

Maximum weight ratings for fifth-wheel hitches range up to 25,500 pounds gross weight, with as much as 25 percent of it on the hitch (most fivers have 20 percent hitch weight or less), and it's best to choose a unit that not only will handle the trailer it will be used to tow, but also any possibility of a larger trailer, although a higher-rated hitch will cost more and will be slightly heavier.

Whether while towing a conventional trailer or a fifth-wheel, the use of a properly rated hitch, adjusted correctly, will ensure a safe and pleasant towing experience. 🚛

AL-KO Kober Corporation, (909) 591-5359, www.rbwindustries.com.

Automatic Equipment Manufacturing, (888) 425-5382, www.aemfg.com.

B&W Truck Beds Inc., (800) 248-6564, www.turnoverball.com.

Draw-Tite Hitches, (866) 308-9054, www.drawtite-hitches.com.

Equal-i-zer Hitch, (800) 478-5578, www.equalizerhitch.com.

Hensley Manufacturing, Inc., (800) 410-6580, www.henslemfg.com.

MOR/ryde International, (574) 293-1581, www.morryde.com.

Pulliam Enterprises, (877) 785-5748, www.pullrite.com.

Reese Division, Cequent Towing Products, (800) 326-1090, www.reeseproducts.com.

Trailair, (800) 998-4238, www.trailair.com.

TrailerSaver Air Ride Hitches, (800) 410-6580, www.trailersaver.com.



Hensley Cub

A Hitch For All Reasons

Whether you're towing a travel trailer or a fifth-wheel, Hensley Manufacturing offers a variety of hitches designed to smooth out the ride.

The Hensley Arrow (for travel trailers between 5,000 and 14,000 pounds) and new Hensley Cub (for travel trailers between 2,000 and 6,000 pounds) are hitch/sway-control devices that permanently mount to your travel trailer's A-frame, eliminating the need for lifting and storing heavy components. These hitches are designed to allow the trailer to track behind the tow vehicle safely by utilizing a unique linkage system. The linkage system also creates the effect of moving the hitch point closer to the rear axle, so the tow vehicle's steering input doesn't exaggerate the trailer's lateral movement — resulting in increased stability (no sway) while towing.

For fifth-wheels, Hensley's TrailerSaver hitches are designed to eliminate both up/down and fore/aft shock in the hitch pin, truck and trailer.

Among the many models offered by Hensley, the new BD3 Air-Ride hitch fits into standard slotted fiver rails, and is designed for easy installation and removal from the truck bed. The BD3 breaks down into two separate pieces (see page 35) to make lifting and storage a snap. Also new is the TS3, which is based on Hensley's popular TSLB hitch. The TS3 fits into standard slotted hitch rails and has been specifically designed for $\frac{3}{4}$ to 1-ton trucks. The TS3 features an operating height of 14 inches and can handle fivers with a pin weight up to 4,500 pounds and an overall weight of up to 20,000 pounds.

Hensley's TrailerSaver hitches all feature a new Smart-Air system that automatically inflates the air bags to the user's desired level of comfort. 



Hensley Arrow

TrailerSaver
TS3TrailerSaver
BD3



Trailer-Brake Control

Technological advances help smooth out the process and improve safety and reliability

BY CHUCK HAMMOCK

Electric-brake systems have been employed for several decades on most trailers that have any significant weight. Each trailer with electric brakes, in turn, also requires that the tow vehicle be fitted with a brake controller.

For years, brake-controller choices have been extensive — all aftermarket and all electronic — but Ford changed the game in 2005 with the first trailer-brake-control (TBC) system included as an integral part of the design of the tow vehicle's design. Ford continues to up the ante, as the TBC is now included in the F-150, making the popular pickup the first in its class to have an integrated brake control. As always, the TBC synchronizes vehicle and trailer brakes for seamless braking (even under heavy load) to provide added driving control and confidence. GM has followed suit, now offering a built-in control on select vehicles.

Until the advent of anti-lock brake systems (ABS), most brake controllers were tapped directly into the hydraulic lines of the tow vehicle's on-board hydraulic-braking system. They were often described as hydraulic/electric brake controllers, as they converted hydraulic pressure in the tow

vehicle's brake system to an electric signal used to activate the trailer's brakes directly proportional to hydraulic pressure in the vehicle's braking system.

A significant factor in elimination of this system was the advent of ABS because vehicle manufacturers' cautioned against tapping into the hydraulic system. The controllers displaced a small amount of brake fluid, and with ABS systems, brake-cylinder volume was more limited, so manufacturers warned not to add controllers that displaced more than 0.02 cubic inches. The tap-in could not occur downstream of the ABS mechanism, so the pressure was on to devise alternate systems.

Electronics were the answer, and many different types of aftermarket brake controllers were developed — none tied in with the tow vehicle's hydraulic system, however. Even in the old days of hydraulic/electric controllers, all were sold in the aftermarket, until Ford became the first to offer a trailer-brake actuation system installed at the factory.

Ford's Braking System

As Ford was first to offer a factory-installed brake controller into the tow vehicle, let's look at

the system. Ford's integrated controller (see the diagram, right) electronically tracks hydraulic pressure inside the vehicle's master cylinder and uses the pressure, along with vehicle speed, to modulate the amount of current produced for trailer brakes. Thus, the system accurately follows tow-vehicle braking — more at high pedal pressure, less at low — even to the point of using ABS. If the wheels of the tow vehicle are slipping, ABS goes into action for the tow vehicle as well as

the trailer. The Ford system doesn't give the trailer the same functions and characteristics of true ABS, but when the truck's ABS is activated, the trailer-brake application is reduced to avoid wheel lockup — just as with true ABS. A dash monitor indicates the level of trailer braking, and a manual override is provided so the trailer brakes can be applied independently of tow-vehicle brakes.

The system cannot be retrofitted to earlier Ford models, and aftermarket controllers still must be used for most other vehicles, so the demand for those aftermarket controllers remains quite large. Accordingly, it's helpful to understand what's out there, and how to make a good choice.

In essence, all electronic brake controllers fall into two general categories: timer-based brake controllers and inertia-based proportional brake controllers. All brake controllers generate an output signal to a trailer-brake system when a user first touches the tow vehicle's brake pedal or activates the brake controller's manual control — if so equipped. What happens next varies greatly, depending on whether you're using a timer-based or proportional brake controller.

While most manufacturers will identify their proportional brake controllers as such, you usually won't see the words "timer-based" in the literature for a nonproportional brake controller. Instead, marketers will sometimes advertise timer-based controllers as having the advantage of requiring no leveling, but even that idea is confusing. Several proportional brake controllers do not require leveling. Timer-based controllers are also touted as being microprocessor-operated, but all brake controllers contain a processor of some kind. Even the most sophisticated timer-based microprocessor doesn't deter-

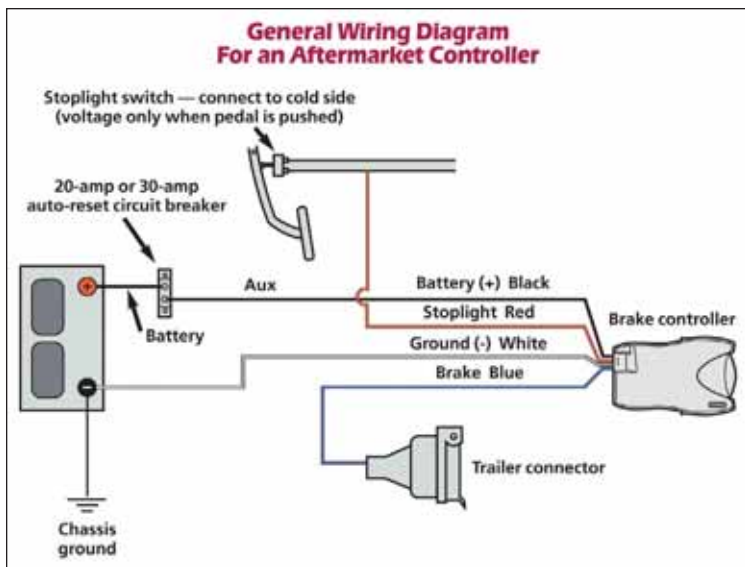

mine how hard you are braking, only how long you've been braking. A good rule of thumb is that if it doesn't say the word "proportional" somewhere in the literature, it's probably a timer-based brake controller.

Timer-Based vs. Proportional

A timer-based brake controller has a timer that generates an output signal for your RV's brakes that increases with the amount of time you keep your foot on the brake pedal. It doesn't know whether you're braking gently on a gradual downhill grade, or if you're in a panic stop. The rate of increase in output (the slope of the voltage ramp) has no bearing on pedal effort, but can usually be adjusted for braking aggressiveness.

An inertia-based proportional controller generates an output that is, as the name suggests, directly proportional to your braking needs. Most proportional brake controllers measure the tow vehicle's rate of deceleration by means of a pendulum. The quicker you slow, the farther the pendulum is displaced, via inertia, from its at-rest position. This creates an electric signal to your trailer's brakes that is proportional to your deceleration rate.

Tekonsha and its sister companies use a series of LEDs and photoelectric detectors in their proportional controllers to determine the position of the displaced pendulum, and therefore determine the deceleration rate. Hayes-Lemmerz uses the Hall effect, a physics principal involving moving magnets, to determine the pendulum's position.

All pendulum controllers are subject to some inaccuracies, as the pendulum can tilt slightly forward or backward on steep grades. Most such controllers employ a damping device to stabilize the



Hensley TruControl



Tekonsha P3

sensor against vibrations, and the damper helps reduce the effect of the fore-or-aft-tilt problem.

The pendulum's position is adjusted through the level-control knob, which allows the pendulum to be oriented to a true vertical resting position to compensate for the angle of the brake-controller body (the "leveling" referred to in some timer-based-controller advertising). The level adjustment also allows the driver to pitch the pendulum slightly forward or aft of its normal resting position to set up the trailer so its braking is aggressive or delayed.

Most drivers prefer some braking effect from the trailer's brakes on the initial touch of the brake pedal, and adjust the brake controller accordingly to provide this so-called threshold voltage. This adjustment produces some output (typically 2 volts), without the initial time period having passed or deceleration having occurred in the two electric brake-controller types. This time period, or deceleration event, is normally needed to activate the timer-based controller or the proportional pendulum-based controller, respectively.

With dozens of different models of brake controllers on the market, many RVers may find the selection of the right controller difficult without some form of guidance. While budgetary considerations may force a user into one category of controller, this is a critical system where pinching pennies may not be advisable.

When faced with the need for a panic stop, most drivers want a controller that will respond in proportion to their braking needs at that moment. Keep in mind that a timer-based controller can't respond in this manner, as its output is fixed for a certain timed duration.

Among more recent developments, accelerometers are being used to measure braking force. Tekonsha has embraced this technology in its Prodigy brake control, and U.S. Gear uses it in the company's system intended for vehicles towed behind motorhomes. Hensley Manufacturing also uses accelerometers in its high-tech TruControl trailer brake control.

Getting Wired

Critical to every successful brake-controller installation is the proper tow-vehicle wiring. While you should carefully follow the manufacturer's recommendations, there are certain common elements to almost every controller.

A reliable power source is a priority, which may include a vehicle manufacturer's built-in circuitry for an aftermarket brake controller. The main power line should be at least a 10 AWG wire from a circuit breaker at the fuse box, or the battery, to the brake controller's power-input connection (follow specific instructions for your controller). The circuit should continue from the controller, without any splices, and terminate at the seven-pin connector found at the rear of your tow vehicle. Most manufacturers advise against grounding the controller to the vehicle's firewall, but recommend routing a 10 AWG (or larger) separate ground wire directly to the battery; the controller may not function properly if the ground connection is not made directly to the battery terminal.

The other connection is made to the brakelight circuit, downstream of the brakelight switch mounted to the brake-pedal assembly, so the controller senses when the brakes have been activated.

Later-model vehicles with towing packages have brake-control wiring bundled under the dash with a plug-in connector attached. A pigtail with the mating part of the connector is supplied with the vehicle and is ready for connection to the brake-control wiring. This setup avoids most of the complexity and possible mistakes with locating the correct wiring among that maze under the dash.

Today's RVer has many choices in brake controllers from many manufacturers. It's important to carefully select the controller that is right for your needs and capable of handling the weight and number of axles on your trailer.

Be sure to follow the manufacturer's written instructions about every aspect of the brake controller's installation, operation, adjustment and maintenance for optimal performance. 🛠️

Anatom

What's in a Towing Package?

Overall packages vary by model, but here are some components that may be included:

- Hitch receiver**
- 4- and/or 7-pin connector**
- Larger alternator**
- Larger battery**
- Larger radiator**
- Additional electric fan(s)**
- Transmission-fluid cooler**
- Engine-oil cooler**
- Rear anti-sway bar**
- Extendible mirrors**
- Vehicle Dynamic Control**
- Integrated brake controller**
- Brake controller pre-wire**
- Synthetic lubricants**
- Lower axle ratio**
- Re-valved shock absorbers**



BY JEFF JOHNSTON

There are many bells and whistles available when choosing a new tow vehicle, but there's one option that is an absolute necessity: The towing package.

There are several good reasons for choosing factory-installed towing hardware. You have full warranty coverage on the equipment. It was designed by the best engineering minds at a major auto manufacturer, which is reassuring when considering the hardware is tying your truck and trailer safely together. You'll probably save money over the cost of aftermarket hardware. And perhaps best of all, use of the factory options means being ready for the road is a turnkey operation that calls for few or no trips to specialty shops after leaving the dealership.

In many cases, you don't have a choice. If the vehicle is to be rated for its highest towing capacity, the towing-package option is mandatory to give the tow vehicle its optimum performance

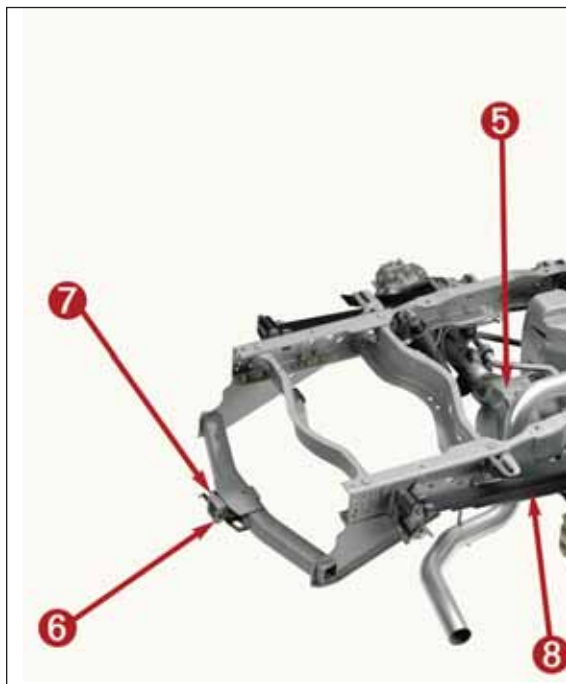

Why of a Towing Package

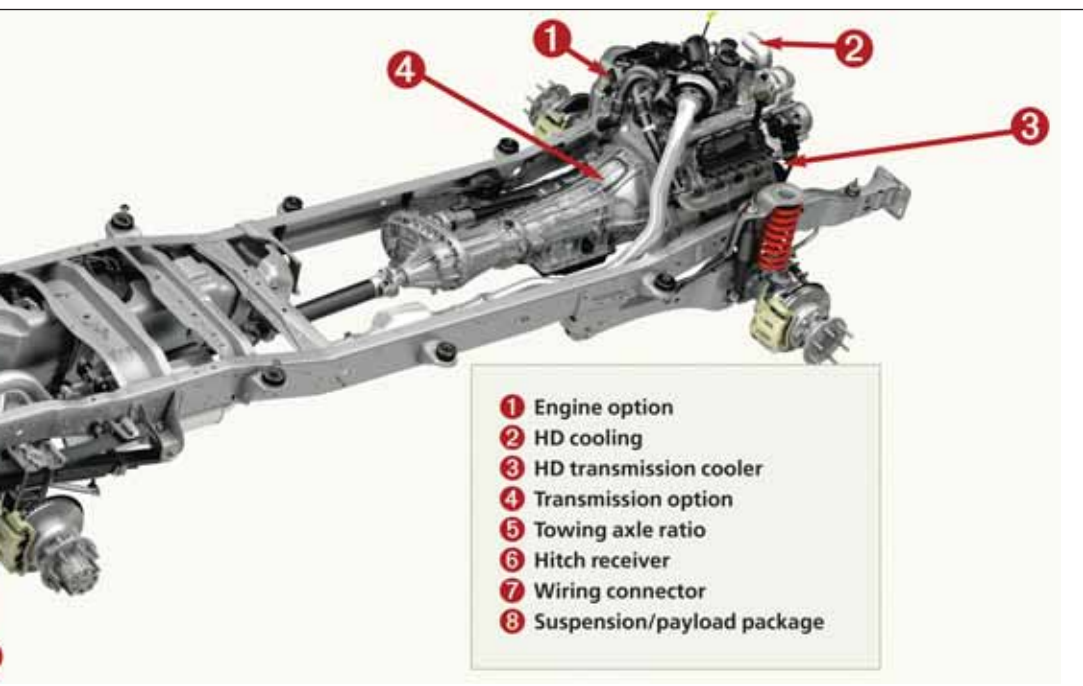



potential. For less-strenuous duty, the towing package is optional.

Check the dealer literature to determine the content of the towing-package option. The following are some of the items you will likely encounter.

Axle Ratio: Most packages include a lower (numerically higher) axle ratio; for example, a 3.73:1 or 4.10:1 instead of the 3.55:1 that comes with the stock vehicle. A lower ratio results in greater torque multiplication at the rear wheels, which means more power for towing. It also means the engine turns somewhat faster for a given road speed, but that's the tradeoff for improved towing performance.

Hitch Receiver: If the tow vehicle already has a receiver, all you need to select is the proper ball mount and the associated hardware, such as a load-distributing hitch. The receiver will be properly matched to the tow vehicle's trailer-towing rating, so you needn't worry about any hitch-overloading situations — as long as you pay attention to the numbers. You'll also avoid interference problems with the exhaust pipe(s), the fuel tank and the spare tire.

Wiring Package: The wiring package is a group of color-coded pigtailed wires near the back bumper that's ready for installation of the trailer-plug receptacle. It can be as complete as a plug or two installed out back, or a pre-wired pigtail for brake-control installation under the dash and full integration with the tow vehicle's electric system.

Alternator: It takes extra charging current to keep a trailer's battery(ies) charged in addition to handling the electrical-power needs of the tow vehicle. The battery itself may also be larger.

Heavy-Duty Suspension: The trailer and its hitch weight add load on the tow-vehicle suspension, so the normal reaction among dealership sales staff and buyers alike is to order the optional heavy-duty (HD) suspension, particularly when fifth-wheel towing is involved. In fact, when the trailer is a conventional ball-type trailer, it's often best not to order a heavy-spring option if there is a choice (if the towing package does not include HD suspension) for trucks rated 8,600 pounds and above because stiff ride and the tendency of the rear springs to do some or most of the work of the load-distributing hitch can be the result. A stiff ride is a very common complaint among owners of $\frac{3}{4}$ -ton and one-ton pickups not towing fifth-wheels.

A case can be made for not ordering an HD suspension even for fifth-wheel towing — except in very high pin-weight situations — opting instead to install auxiliary springs or air bags after delivery to support the pin weight (if necessary), which allows a more civilized ride on standard rear springs while not towing. It's necessary to compare the standard and optional rear-axle-weight ratings relative to the anticipated trailer pin weight. It's easy to upgrade rear suspensions after a truck is built, but nearly impossible to soften the ride of an oversprung truck without replacing the suspension.



Ford's folding mirrors require less space than conventional mirrors when folded, and offer a clear view of the side of the trailer when they're extended for towing.

SUVs have enough of their body weight on the rear axle, so that's generally not an issue.

Brake Control: Ford's Super Duty was the original tow rig to offer a factory-installed brake controller, and GM followed suit the following year. Otherwise, towing packages usually include a trailer-wiring harness with a circuit for an after-market brake-control unit — a very worthwhile component of the package.

Stability Control: More manufacturers are now offering electronic stability control.

Mirrors: Many towing packages offer mirrors

designed to be extended outward while towing trailers.

Extra Cooling: The largest possible radiator, a larger transmission-oil cooler and often a power-steering-fluid cooler are essential parts of the usual HD cooling component of a towing package, and we advise that no tow vehicle should be ordered without them.

These components will not only help the tow vehicle avoid overheating any vital functional parts, but they will also lead to longer trouble-free component service life. 🚚

Trailer Sway Control only DAMPENS trailer sway

Eliminate trailer sway completely!

Hensley® Towing Systems are
**Guaranteed to
Eliminate Trailer Sway.**

Call one of our Towing Specialists today
and ask which Hensley® is right for you.



Keep your family safe.

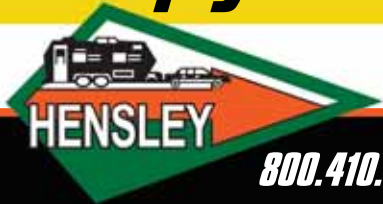

Call or visit us online **Free Video**

800.410.6580 • www.HensleyMfg.com



Towing Tips

Plenty of practice and defensive driving skills lead to safe and enjoyable towing

BY BRAD CLAYTON

Towing a trailer is certainly not brain surgery, but it does represent a step up in complexity from driving a solo vehicle, requiring new awareness of combined vehicle length, trailer width, braking distance, turning characteristics and several other vital factors that must be considered while towing a trailer.

Most of us drive trucks, SUVs or passenger cars daily, and graduate to RVs only occasionally. Thus, it's always necessary to make a mental transition and try to keep the size and handling characteristics of the larger rig in mind.

Allowing solo-vehicle habits to take over may result in a tendency to make turns too tightly, run over curbs, hit stationary objects such as overhanging tree limbs or to follow too closely.

Be Aware

The first towing precautions are those that precede towing — matching the tow vehicle and trailer correctly, adhering to weight limits and making sure hitch selection and adjustment are correct, as described elsewhere in this guide. And it's also important to refresh defensive driving skills. From there, the real fun begins.

The combined length of tow vehicle and trailer, as well as the combined weight, must be in the forefront of your mind, right from the start. Maintaining extended following distances is one of the most important towing-related driving habits that initially is difficult to adhere to because we tend to fall into our typical driving habits.

Even though trailer brakes may be functional, braking distances almost always are extended. It's also important to make lane changes carefully and slowly, and to allow extended distances for passing. High-quality, solidly mounted extendible mirrors with large reflective areas — adjusted properly — are also essential.

Speedy traffic seems more tolerant of slow 18-wheelers than of slow RVs, which makes courtesy an important safety factor for RV owners because an irate driver trying to pass can be a serious safety threat; courtesy is not only the consideration of others, it's a safety issue. Frequent monitoring of rearview mirrors is necessary; when a vehicle is tailgating and trying to pass, we should help by driving slightly to the right to give the other driver a better view of the road ahead, even if a passing opportunity does not exist at the time. We should use turnouts whenever possible and avoid following another vehicle so closely that a vehicle overtaking from the rear cannot return to the proper lane.

Brake Time

While RV brakes are adequate for most situations, care is necessary to avoid overheating, which can lead to brake fade. If brake fade occurs, it will likely be on steep downgrades. If this happens, friction will raise the temperature of brake pads and linings to extremely high levels, resulting in temporary loss of braking.

The cure is prevention, such as downshifting to a gear range that is low enough to retard speed sufficiently that brakes need not be used more than occasionally. This way, enough braking performance is reserved to make an emergency stop, should it become necessary.

When braking on a grade is necessary, apply the brakes intermittently, with moderate pressure, and release the pedal to allow the brakes to cool.

The action of electric trailer brakes should be apparent to the driver, and sufficient enough to handle the trailer's weight. The controller should be adjusted so that maximum braking action

does not cause trailer-wheel lockup. Improper controller adjustment is a major cause of inadequate braking, so it's wise to study the manufacturer's instructions. Travel-trailer instability (fish-tailing) should not occur in a well-balanced, well-hitched combination, but if it does, independent actuation of trailer brakes usually will bring the trailer back into line.

On the Right Track

All trailers require more space for turns, and

travel trailers follow the tow-vehicle track more closely than do fifth-wheels, which track farther to the inside of a turn. There is need for continual awareness, which should eventually become second-nature after a modest amount of on-the-road experience.

Fifth-wheel trailers are different to back than conventional trailers, and require more practice for someone accustomed to backing a conventional trailer. A well-used technique involves plac-

ing one's hand at the bottom of the steering wheel and moving it in the same direction the trailer is intended to go. It's more effective with travel trailers than with fifth-wheels, which often require more turning of the steering wheel. Handheld two-way radios can allow an assistant to more effectively relay backing instructions to the driver.

Before each trip, it's essential to check the tires to assure that inflation pressures match those molded on tire sidewalls (cold), or that they are appropriate for your load (consult both the tire and vehicle load/inflation tables). Also, be sure to inspect all vehicle fluids, per standard maintenance procedure during heavy-duty vehicle use cycles, and make sure trailer-wheel lug nuts are tightened to factory specifications.

Trailer is a great way to explore the new horizons and a great way to check out the wonderful camping destinations that are available to owners of recreational trailers. But always keep in mind that defensive driving will pay off in safe travel. 🚚



Rules of the Road

STATE OR PROVINCE	SIZE LIMITS						EQUIPMENT REQUIRED						RIDING PERMITTED			
	Height (ft)	Width (ft)	Trailer Length (ft)	Motorhome Length (ft)	Two-Vehicle Combined Length (ft)	Triple Towing Allowed	Safety Chain	Breakaway Switch	Fire Extinguisher in RV	Flares or Reflective Signs	Weight of Trailer Requiring Brakes (Unladen) (lb)	Wipers On/Lights On	In Fifth-Wheel Trailer	In Pickup Camper	In Travel Trailer	Overnight Parking Permitted in State Rest Areas
Alabama	13½	8½	40	45	65 ¹⁰		•	• ¹¹	• ¹²		3,000	•				P
Alaska	14	8½	40	45	75		•	• ¹¹		•	5,000					•
Arizona	13½	8½ ¹⁶	40	45	65	• ¹⁷	•	• ¹¹			3,000 ¹¹		•	•	•	•
Arkansas	13½	8½	43½	45	65	•	•	• ⁷	•		3,000 ¹¹	•				•
California	14	8½	40	45 ¹⁷	65		•	•	•	•	1,500 ¹⁷	•	• ¹⁸	• ¹⁹		P
Colorado	13	8½	NS	45	75 ²⁰	• ²¹⁻²²	• ⁴	•			3,000 ¹⁷		•	•	•	
Connecticut	13½	8½	NS	45	65 ^{1,18}		•	•	•	•	3,000 ¹⁷	•				P
Delaware	13½	8½	40	45	65		•	•		•	4,000	•				P
District of Columbia	13½	8 ¹⁶	NS	40	55	•	•	•			3,000 ¹¹					
Florida	13½	8½ ¹⁶	40	45	65		•	•	•	•	3,000 ¹¹	•				
Georgia	13½	8½	NS	45	60		•	•	•	•	1,500	• ²³			• ¹⁵	
Hawaii	14	9	48	45	65		•	• ¹		•	3,000 ¹¹				• ¹⁰	
Idaho	14	8½	48	45	75	• ²⁴		•			1,500				•	P
Illinois	13½	8½	45 ¹⁶	45	60	• ^{16,25}	• ²⁶	• ²⁶		•	3,000 ¹¹	•			•	
Indiana	13½	8½	40	45	60	• ¹¹	•	•		•	3,000 ¹⁷		•	•	•	•
Iowa	13½	8½	53	45	65	• ²⁷	•	•		•	3,000		•	•	•	P
Kansas	14	8½	NS	45	65	• ¹¹	• ¹⁷	• ¹⁶	• ¹⁶	• ¹⁶	• ¹⁶	• ¹⁶	• ¹⁶	• ¹⁶	• ¹⁶	P
Kentucky	13½	8½	NS	45	65	• ¹¹	•	•	•	•	3,000 ⁵	•				
Louisiana	14	8½	40	45	70	• ²⁸	• ¹	• ³		•	3,000					P
Maine	13½	8½	48	45	65		•	•			3,000	•				P
Maryland	13.6	8½	40	40	55	• ²⁹		•	• ³⁰	• ³⁰	3,000 ⁷	•	•	•	•	P
Massachusetts	13½	8½	40	45	60		•	•			10,000					• ¹
Michigan	13½	8½	45	45	65	• ¹⁶	•	•			3,000		•	•	•	P
Minnesota	13½	8½	45	45	70	• ¹⁶	•	• ⁷		•	3,000 ¹⁷	•	•	•	•	P
Mississippi	13½	8½	40	45	53	•	•	•		•	2,000 ¹¹					
Missouri	14 ¹⁷	8½	NS	45	65 ¹⁷	• ^{16,31}	• ¹⁷				NS		•	•	•	•
Montana	14	8½ ¹⁶	NS	55	65	• ³²	•	•		•	3,000		•	•		P
Nebraska	14½	8½	40	45	65	• ¹¹	•	• ⁷		•	3,000		•	•	•	
Nevada	14	8½	NS	45	70	• ³³	•	• ⁷			1,500					P
New Hampshire	13½	8½	48 ¹⁶	45	NS		•	•			3,000					
New Jersey	13½	8 ¹⁶	40	40	62		•	•		•	3,000	•	•	•		P
New Mexico	14 ¹	8½	40	45	65	•	•	•		•	3,000 ¹⁷					P
New York	13½	8½ ¹⁷	48	45	65		•	•			1,000 ³	•	•	•		P
North Carolina	13½	8½	35	45	60		•	•			4,000	•	•	•		P

NOTE: While every attempt has been made to verify this information, Trailer Life cannot guarantee its accuracy and assumes no responsibility for errors or omissions. Changes may have been made since this data was compiled. Call state and provincial tourism offices for additional details.

•• indicates "yes," item is permitted or required.
 NS indicates not specified.
 L indicates legislation pending to increase length allowance.
 P indicates "as posted." Information is based on latest available data; laws may have changed since press time.

- ¹ On designated rural interstates; some exceptions.
- ² Required on trailers weighing more than 3,000 lb.
- ³ Prohibited where posted.
- ⁴ Required on trailers weighing more than 3,000 lb or if gross weight of

- trailer exceeds empty weight of tow vehicle.
- ⁵ Required on trucks weighing more than 3,700 kg.
- ⁶ Required if weight of trailer exceeds 40 percent of tow-vehicle weight.
- ⁷ Required on trailers weighing more than 6,000 lb.
- ⁸ Required if gross weight is more than 2,500 kg.
- ⁹ Required on trailers more than 1,000 lb unladen, or 3,000 lb laden.
- ¹⁰ Riding in fifth-wheel with audible or visual device with tow vehicle and safety glass.
- ¹¹ 24-hour limit.
- ¹² Required if trailer exceeds 50 percent of tow-vehicle weight. BC, YT: laden.
- ¹³ Trailer limited to 48 ft in a 60-ft combination.
- ¹⁴ Eight-hour limit; 3 hours in SO.
- ¹⁵ Only if required by CSA at time of manufacture.
- ¹⁶ 8½ ft on certain federal road systems.
- ¹⁷ Gross weight requiring brakes.
- ¹⁸ Must have free access to drive compartment.

and Towing Laws

STATE OR PROVINCE	SIZE LIMITS						EQUIPMENT REQUIRED					RIDING PERMITTED			Overnight Parking Permitted in State Rest Areas
	Height (ft)	Width (ft)	Trailer Length (ft)	Motorhome Length (ft)	Two-Vehicle Combined Length (ft)	Triple Towing Allowed (ft)	Safety Chain	Breakaway Switch	Fire Extinguisher in RV	Flares or Reflective Signs	Weight of Trailer Requiring Brakes (Unladen) (lb)	Wipers On/Lights On	In Fifth-Wheel Trailer	In Pickup Camper	
North Dakota	14	8½	53	50	75	• ⁴¹	•	•	•	•	3,000	•	•	•	•
Ohio	13½	8½	53	45	65	• ⁴¹	•	•	•	•	2,000 ¹¹	•	•	•	•
Oklahoma	13½	8½	40	45	65	• ⁴¹	•	•	•	•	3,000	•	•	•	•
Oregon	14	8½	45	45	65 ¹⁸	•	•	•	•	•	•	• ⁴⁵	•	•	• ⁴⁵
Pennsylvania	13½	8½ ³⁸	NS ⁴	45	60	•	•	•	•	• ¹⁵	•	• ⁴⁵	•	•	•
Rhode Island	13½	8½	NS	40	60	•	•	•	•	•	4,000	•	•	•	•
South Carolina	13½	8½	48	45	NS	•	•	•	•	•	3,000 ¹¹	•	•	•	P
South Dakota	14 ⁷	8½	53	45	80	• ⁴⁵ , ⁴⁵	•	•	•	•	3,000	•	• ⁴⁵	•	P ¹¹
Tennessee	13½	8½	40	45	65	• ⁴¹	•	• ²	•	•	1,500	•	•	•	•
Texas	14	8½	NS	45	65	• ⁴¹	•	• ²	•	•	4,500	•	•	•	P ¹¹
Utah	14	8½	40	45	65	• ⁴¹ , ⁴¹	•	• ²	•	•	2,000	•	•	•	P ¹¹
Vermont	13½	8½	53	46	68	•	• ²	•	•	•	3,000	•	•	•	P
Virginia	13½	8½	45	45	65	•	• ²⁸	•	•	•	3,000	•	•	•	P
Washington	14	8½	53	46	75	•	• ²	•	•	•	3,000	•	•	•	• ⁴⁵
West Virginia	13½	8½	40	45	65	•	•	•	•	•	3,000 ^{11,11}	•	•	•	•
Wisconsin	13½	8½	48	45L	65	65 ¹³	•	•	•	•	3,000 ¹¹	•	• ⁴⁵	•	•
Wyoming	14	8½	60	60	85	81	•	•	•	•	• ⁴⁵	•	•	•	P

CANADA (METRIC)

Alberta	4m	2.6m	12.5m	13m	20m	• ⁴²	• ⁴³	• ⁴⁴	• ⁴⁴	•	910 kg ¹²	•	•	•	•
British Columbia	4.15m	2.6m	12.5m	14m	20m	•	•	•	•	•	1,400 kg ¹²	•	•	•	•
Manitoba	4.15m	2.6m	12.5m	14m	21.5m	• ⁴⁶	•	•	•	•	910 kg ¹²	•	•	•	•
New Brunswick	4.15m	2.6m	12.5m	12.5m	21m	•	•	•	•	•	•	•	•	•	P
Newfoundland & Labrador	4.15m	2.6m	12.5m	12.5m	23m	•	• ⁴³	• ⁴²	• ⁴²	•	• ⁴⁵	•	NS	•	P
NW Territories	4.2m	2.6m	NS ⁴⁷	12.5m	NS ⁴⁷	•	•	•	•	•	1,360 kg	• ⁴⁸	•	•	P
Nova Scotia	4.15m	2.6m	12.5m	14m	23m	•	NS	•	•	•	1,800 kg	•	• ⁴⁹	•	P
Ontario	4.15m	2.6m	12.5m	14m	23m	•	•	•	•	•	1,360 kg ¹²	•	•	•	P
Prince Edward Island	4.15m	2.6m	12.5m	14m	23m	•	•	•	•	•	1,500 kg	•	NS	NS	•
Quebec	4.15m	2.6m	12.5m	14m	23m	• ⁴¹	• ⁴⁵	• ⁴⁵	• ⁴¹	•	1,300 kg ¹³	•	• ⁴⁹	•	P
Saskatchewan	4.15m	2.6m	12.5m	14m ¹¹	23m	• ⁴¹	•	•	•	•	1,360 kg ¹⁴	•	• ⁴⁹	•	P
Yukon	4.15m	2.6m	16.15	12.5m	25m	•	•	•	•	•	910 kg ¹²	• ⁴⁸	•	NS	P

NOTE: 2.6m = 8½ ft; 12.5m = 41 ft; 16.15m = 53 ft; 20m = 65 ft; 23m = 75 ft.

⁴⁴ Maximum combined length 60 ft on select high-ways. Special permit in OR, MI maximum length 70 ft. WA maximum 56 ft with permit.

⁴⁵ At least one exit that can be opened from outside and inside.

⁴⁶ Not to exceed 18 hours in any two-week period.

⁴⁷ Headlights or daytime running lights required at all times.

⁴⁸ 12-hour limit.

⁴⁹ Must be able to stop in 40 ft at 20 mph.

⁵⁰ On interstate highways; secondary roads still 8 ft.

⁵¹ 8-ft ft on all state routes. On some other roads 8-ft limits are posted.

⁵² Some exceptions or restrictions. CA: See www.dot.ca.gov.

⁵³ Special wide-body regulations.

⁵⁴ Two safety chains or breakaway switch required on trailers.

⁵⁵ Required if RV is wider than 2 m.

⁵⁶ Not recommended.

⁵⁷ Seats must be equipped with safety belts.

⁵⁸ 14 years of age and older; 13 or older in HI.

⁵⁹ Required on trailers weighing 3,000 lb and more.

⁶⁰ If passenger can communicate with driver, and exit can be opened from both interior and exterior. CA: Seat belts required. OR: Safety glass in windows required.

⁶¹ Suggested, but not required.

⁶² Required on bumper hitches only.

⁶³ Required if gross weight is more than 1,350 kg.

⁶⁴ Headlights must be used when visibility is < 500 ft.

YT: always, outside of city.

⁶⁵ Total maximum combined length of 75 ft.

⁶⁶ Total maximum combined length of 65 ft. QC: 19 m.

⁶⁷ Total maximum combined length of 70 ft.

⁶⁸ With certain qualifications. Only with fifth-wheel trailer in AB, AZ, IL, MI, MN, NB (maximum length 23 m), SK and YT.

⁶⁹ Total maximum length of 72 ft.

⁷⁰ See state and provincial regulations, SK 14 m with permit.

⁷¹ Total maximum combined length of 60 ft.

⁷² Total maximum combined length of 21 m.

⁷³ Total maximum combined length of 23 m.; ball hitch OK on fifth-wheel only.

⁷⁴ Total maximum combined length of 20 m.

⁷⁵ Total maximum combined length of 55 ft.

⁷⁶ NT — 4,500 kg gross vehicle weight rating requires ABC type fire extinguisher.

⁷⁷ NH — 53-ft trailer permitted on special routes.

⁷⁸ AL — Truck tractors and semi-trailers only. All other vehicles may not exceed 57-ft total length combined.

⁷⁹ IL — Required on all trailers in IL with a gross vehicle weight in excess of 5,000 lb.

⁸⁰ S — Applies to all trailers except those utilizing a fifth-wheel type connection.

⁸¹ IL — No semi-trailer shall exceed 53 ft.

ALL-NEW '09 F-150
This thing's gonna
save you gas and sweat.

21
MPG*

AND more horsepower.



FIND OUT MORE AT FORDVEHICLES.COM

*EPA-estimated 15 city/21 highway mpg on SuperCrew 4x2 models with SFE Package.

Go To: **TRAILER**
FOLLOW THE ROAD TO ADVENTURE
LIFE.com

User Guide

Contents



Welcome to our digital edition of Trailer Life Magazine. This format makes it easy for you to navigate the magazine and provides direct links to Internet sites of our advertisers, our TrailerLife.com Web site, and many Web sites to supplement our editorial features.

Here are some tips on how to use Digital Trailer Life:



- Click on the TrailerLife.com button to go directly to our Web site.
- Click on the User Guide button on any page to bring you back to this page.
- Click on the Contents button to take you to the Table of Contents page from anywhere in the magazine.

- When the hand icon changes to a pointing  finger, it indicates a link to a Web site or to another page in the magazine.

- Use the Zoom  tool to zoom in on the page. Use the Zoom-out tool  and hold down the option (Macintosh) or Windows key to toggle back and forth.

- Click and drag using the Dynamic Zoom  tool to infinitely control the zoom.

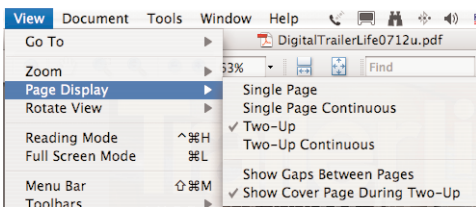

We recommend a Page Layout view of Two-Up (or Facing, depending on the version of Reader), Showing Cover Page, however, Adobe Reader provides several options you may prefer.

We hope you enjoy reading our Digital *Trailer Life* magazine, and we encourage your comments and suggestions to our editor at kbunker@affinitygroup.com